

ATA5088

Digital Contact Controller

OVERVIEW

The ATA5088, ATLab's latest touch sensor IC, is designed especially for the applications which do not have I²C interface or want to replace mechanical switches without any firmware modification. It provides pre-defined sensitivity values stored at internal ROM area and these values can be selected a few pin options. Also, touch output is transmitted to the host MCU by open collector output pins. In order to utilize a filter function called APIS (Adjacent Pattern Interference Suppression) which screens weekly touched keys, there is a pin to select either APIS mode 1 which outputs the strongest touched key or APIS mode 2 which outputs all touch keys beyond pre-defined thresholds. It still provides I²C interface for tuning the touch application with the speed of 100Kbps and reading touch information such as touch data, capacitance data and other accessible read only registers.

The ATA5088 uses time-domain multiplexing (TDM) architecture to measure capacitance variations of input channels and uses an optimized internal voltage regulator with a smart power management scheme in order to significantly reduce power consumption. The ATA5088 also adopts active pulse-pass architecture to improve noise immunity to achieve better performance in noisy environments.

In addition to these major changes in technology, the ATA5088 has the internal DAC circuit for communication interface. The ATA5088 has a total of 8 channels and touch information of these channels is conveyed through 8 open collector output pins or Internal DAC or I²C interface. All the previously existing functions such as APIS, AIC, FILTER, and upgraded 10-bit capacitance data, etc. still remain in the ATA5088.

One of benefits using the ATA5088 is its low power consumption capability. It consumes only 150uA in active mode, 50uA in idle.

FEATURES

- Patented fully digital architecture
- Extremely low power consumption
- Supports 8 input channels (32QFN, 30SSOP) , 6channels(24SSOP) and 3channels(16QFN,16SOP)
- Programmable registers to characterize applications
- I²C interface with the host MCU(Up to 100KHz Speed Mode)
- Configurable AICTM (Automatic Impedance Calibration)
- One types of interrupts (TINT for touch detection)
- 8-bit resolution of touch strength data (256 steps)
- Two different modes for APISTM (Adjacent Pattern Interference Suppression)
- Configurable DIO pins as direct touch outputs, extended GPOS
- Supports 8 channels open drain type touch outputs.
- Support 1 channel CMOS output for power switch
- Supports 2 channels internal DAC output for touch state.

APPLICATIONS

- Portable devices such as PDA's, cellular phones, MP3 players, remote controllers, and other integrated input devices
- Home appliances and consumer electronic products
- Computer input devices such as mice and keyboards

Table of Contents

Ordering Information	3
Package Pinouts	3
Electrical Characteristics	5
Operation Principles	6
Touch Detection	6
AIC™ (Automatic Impedance Calibration)	7
APIS™ Touch Output	7
Communication Specifications for I²C	8
Application Information	10
32-pin Package (32QFN)	10
16-pin Package (16QFN)	14
30-pin Package (30SSOP)	17
24-pin Package (24SSOP)	21
16-pin Package (16SOP)	25
Power Connections	28
Power Sequence	29
Power State	30
Tuning System	30
Hardware	30
Software	31
Package Dimensions	32
32QFN	32
16QFN	33
24SSOP	34
16SOP	35
30SSOP	36
Product Inquiry	37

Ordering Information

Product Code	Package Type	Package Dimension	Pin Pitch	Number of Sensor Inputs	Number of Digital Outputs
ATA5088DA-32N	32QFN	5mm x 5mm x 0.85mm	0.5mm	8	9
ATA5088DA-16N	16QFN	4mm x 4mm x 0.6mm	0.65mm	3	3
ATA5088DA-24S	24SSOP	8.2mm x 7.7mm X 2mm	0.65mm	6	6
ATA5088DA-16P	16SOP	9.9mm x 6mm X 1.8mm	1.27mm	3	3
ATA5088DA-30S	30SSOP	12.7mm x 10.3mm x 2.5mm	0.8mm	8	9

Package Pinouts

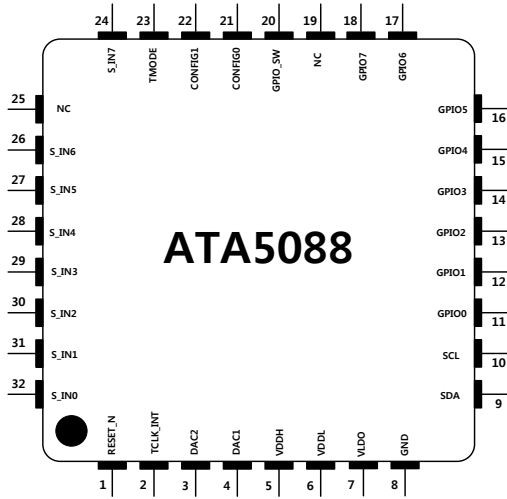

32QFN

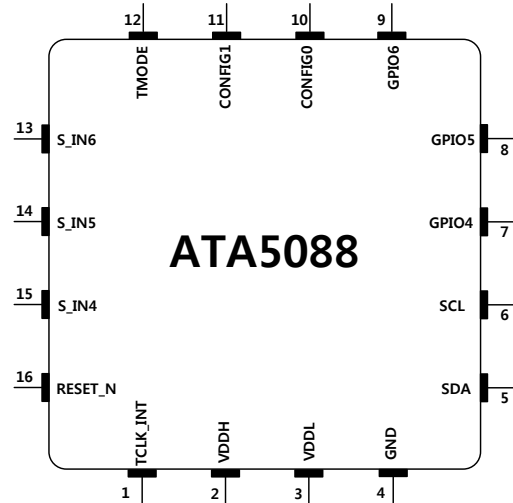

16QFN

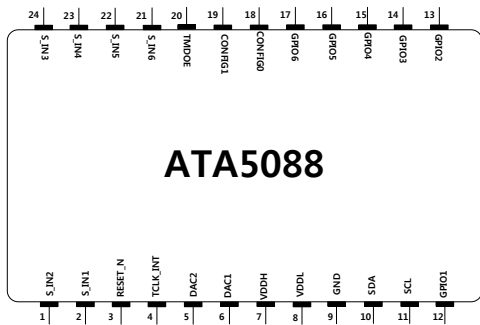

24SSOP

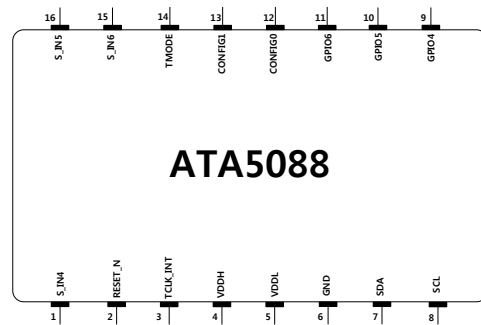

16SOP

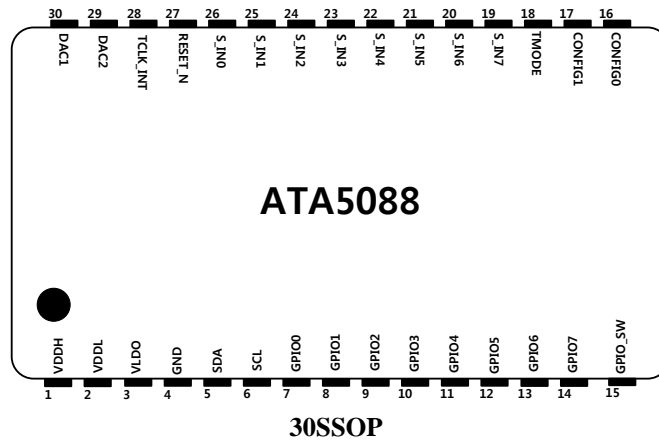

Electrical Characteristics

Symbol	Parameter	Conditions	Min.	Typ.	Max.	Unit
ABSOLUTE MAXIMUM RATINGS						
Tstg	Storage Temperature		-45		95	°C
Topr	Operating Temperature		-40		90	°C
Hopr	Operating Humidity		5		95	%
VPH	Power Supply Voltage	VPH should be higher than 3V when using internal LDO	3.0	3.3	5.5	V
V25	Power Supply Voltage(V25)		2.3	2.5	2.7	V
Vin	Input Voltage		2.3	2.5	2.7	V
RECOMMENDED OPERATING CONDITIONS						
Toprr	Operating Temperature		-35	25	85	°C
Vddp	Power Supply Voltage (VPH)		-		5	V
Vddc	Power Supply Voltage (V25)		2.4	2.5	2.6	V
Tr_i	Digital Input Rising Time				5	ns
Tf_i	Digital Input Falling Time				5	ns
AC ELECTRICAL SPECIFICATIONS (Typical values at Ta=25°C and VPH=3.3V and default Conditions)						
fsmp	Touch Sample frequency		10	200	5000	Hz
Stch	Touch Sensitivity			0.091		pF
Tr_o	Output Rising Time	Load = 100pF		50	60	ns
Tf_o	Output Falling Time	Load = 100pF		50	60	ns
DC ELECTRICAL SPECIFICATIONS (Typical values at Ta=25°C and VPH=3.3V, using Internal LDO)						
Idd_a	Supply Current (Active mode)		-	140	-	μA
Idd_i	Supply Current (Idle mode)		-	50	-	μA
Vil	Digital Input Low Voltage				0.7	V
Vih	Digital Input High Voltage		0.8xVPH			V
Vol	Digital Output Low Voltage				0.6	V
Voh	Digital Output High Voltage		VPH-0.5			V
Vldo	Internal LDO Output Voltage		2.3	2.5	3.0	V
Ildo	Internal LDO Driving Current				20	mA
Ids	GPIO Sinking Current		-	-	16	mA
Ids_d	Digital IO Driving Current		-	-	2	mA
Vdac1	Internal DAC1 Output Voltage	S_IN0~S_IN3 No-Touch Period	-	3.3V	-	V
		S_IN0 Touch Period	0.63	0.67	0.71	V
		S_IN1 Touch Period	1.01	1.07	1.13	V
		S_IN2 Touch Period	1.30	1.37	1.44	V
		S_IN3 Touch Period	1.58	1.67	1.75	V
Vdac2	Internal DAC2 Output Voltage	S_IN4~S_IN7 No-Touch Period	-	3.3V	-	V
		S_IN4 Touch Period	0.63	0.67	0.71	V
		S_IN5 Touch Period	1.01	1.07	1.13	V
		S_IN6 Touch Period	1.30	1.37	1.44	V
		S_IN7 Touch Period	1.58	1.67	1.75	V

Operation Principles

Touch Detection

ATA5088 includes ATLab's proprietary technology of Impedance Change Detection engine within the device. It detects impedance difference between reference and sensor input.

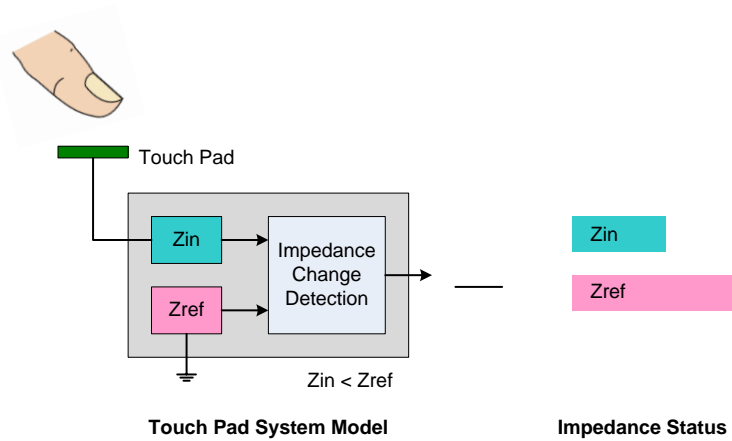

Figure 1: When a Pad is Not Touched.

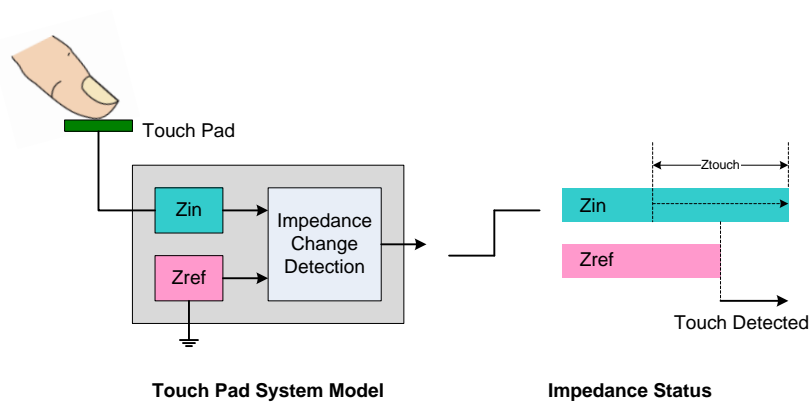

Figure 2: When a Pad is touched.

As shown in Figure 1, if the pad is not touched, the impedance of the sensor input Z_{in} should be kept less than the impedance of the reference Z_{ref} . If the pad is touched, as shown in Figure 2, Z_{in} is increased by Z_{touch} . When Z_{touch} by touching becomes greater than the difference of Z_{in} and Z_{ref} in the not touched state, i.e., if Z_{in} in touched state becomes greater than Z_{ref} by a value higher than 0.091pF , the ICD (Impedance Change Detection) engine within the chip generates the acknowledged output signal indicating it senses the touch.

$$\text{ICD} = \begin{cases} 1, & \text{if } Z_{\text{touch}} > 0.091\text{pF} \\ 0, & \text{otherwise} \end{cases}$$

Notice the higher value of 0.058pF is needed to maintain stable output against various noises. The sensor input impedance, Z_{in} , includes parasitic capacitance of the input line, tuning capacitance of input pin and on-chip input impedance, while Z_{ref} includes on-chip impedance, AIC control values and external tuning capacitance if necessary.

AIC™ (Automatic Impedance Calibration)

AIC function, ATLab's patented technology, is to maintain consistent sensitivity against external environmental changes such as temperature, supply voltage/current, humidity, and system-level variations. This helps users to develop their applications more conveniently by providing the actual impedance value of each sensor input. For developers, a Tuning Viewer program is provided, which helps to optimize PCB design and to decide AIC input parameters. More detailed information is available in the ATA5088 Tuning Guide.

The ICD engine residing in the ATA5088 controls reference impedance values for each sensor input pin by acquiring each input impedance data. It periodically updates all reference values under the condition that all twelve touch pads remain in no-touched status. This auto-calibration function absorbs environmental changes and guarantees product stability.

APIS™ Touch Output

When touch pads are arranged too closely to each other, it is sometimes difficult to identify which pad is touched. APIS™ (Adjacent Pattern Interference Suppression) is a filtering function to identify which pads are intentionally touched. If APIS mode is not defined, all touch data without APIS filtering are transmitted to the MCU. For example, if the application is a numeric keypad, the user can use APIS mode 1 to get the strongest output and filter out all other weakly touched inputs. Without APIS, the host may have to do this filtering function and hence APIS will reduce the burden of the host computing time.

There are two modes in APIS:

- APIS mode 1:** Reports the strongest output only (Figure 3). Divided into two groups, S0~S3 and S4~S7 can report the strongest outputs by each. One strongest output comes from S0~S3 and the other comes from S4~S7 at over 30pins package.
(16pins package:S1~S3, 24pins package: S1~S3, S4~S6)
- APIS mode 2:** Reports all outputs that exceeds pre-defined thresholds (value of Strength Threshold register) (Figure 4).

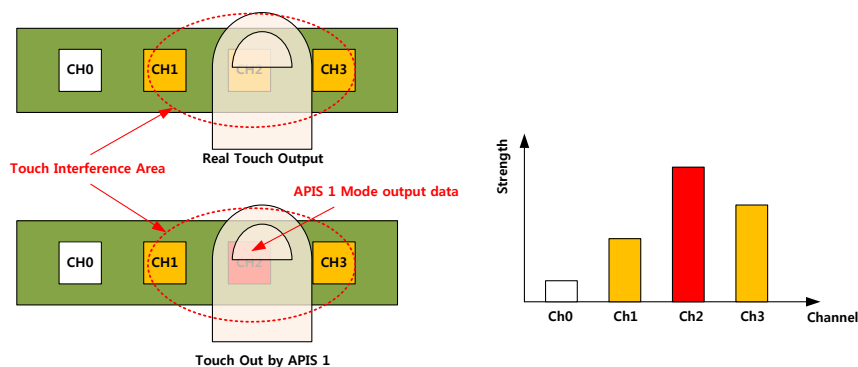

Figure 3: Operation of APIS mode 1

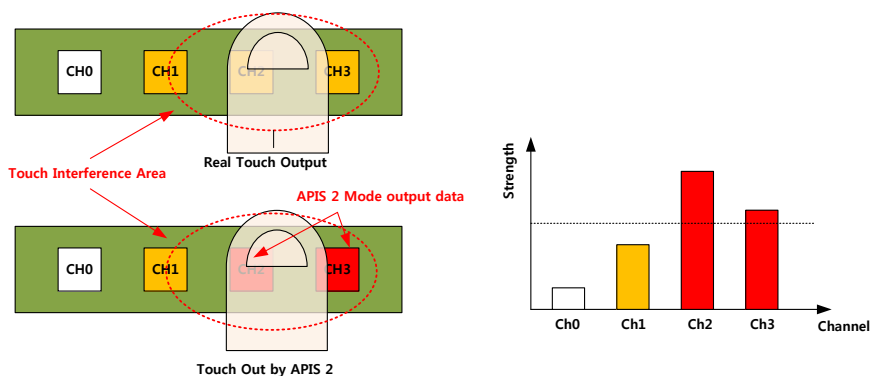

Figure 4: Operation of APIS Mode 2

Communication Specifications for I²C

ATA5088 is only support standard-mode.

Table 1: DC Electrical Specifications for I²C Bus

Symbol	Parameter	Standard-Mode		Fast-Mode		Unit
		Min.	Max.	Min.	Max.	
V_{IL}	LOW Level Input Voltage:					
	Fixed Input Levels	-0.5	1.5	n/a	n/a	V
	V _{DD} Related Input Levels	-0.5	0.3 x V _{DD}	-0.5	0.3 x V _{DD} ⁽¹⁾	V
V_{IH}	HIGH Level Input Voltage:					
	Fixed Input Levels	3.0	⁽²⁾	n/a	n/a	V
	V _{DD} Related Input Levels	0.7 x V _{DD}	⁽²⁾	0.7 x V _{DD}	⁽²⁾	V
V_{hys}	Hysteresis of Schmitt Trigger Inputs:					
	V _{DD} > 2V	3.0	⁽²⁾	n/a	n/a	V
	V _{DD} < 2V	0.7 x V _{DD}	⁽²⁾	0.7 x V _{DD}	⁽²⁾	V
V_{OL1}	LOW Level Output Voltage (open drain or collector) at 3mA Sink Current:					
	V _{DD} > 2V	0	0.4	0	0.4	V
V_{OL3}	V _{DD} < 2V	n/a	n/a	0	0.2 x V _{DD}	V
t_{of}	Output Fall Time from V _{IHmin} to V _{ILmax} with a Bus Capacitance from 10pF to 400pF		250 ⁽⁴⁾	20 + 0.1C _b ⁽³⁾		ns
t_{sp}	Pulse Width of Spike which must be suppressed by the input filter	n/a	n/a	0	50	ns
I_i	Input Current each I/O Pin with an Input Voltage Between 0.1V _{DD} and 0.9V _{DDmax}	-10	10	-10 ⁽⁵⁾	10 ⁽⁵⁾	μA
C_i	Capacitance for each I/O pin		10		10	pF

Note:

1. Devices that use non-standard supply voltages which do not confirm to the intended I²C bus system levels must relate their input levels to the V_{DD} voltage to which the pull-up resistors R_p are connected.
 2. Maximum V_{IH} = V_{DDmax} + 0.5V.
 3. C_b = capacitance of one bus line in pF.
 4. The maximum t_f for the SDA and SCL bus lines quoted in Table 2 (300ns) is longer than the specified maximum t_{of} for the output stages (250ns). This allows series protection resistors (R_s) to be connected between the SDA/SCL pins and the SDA/SCL bus lines as shown in Figure 5 without exceeding the maximum specified for t_f.
 5. I/O pins of Fast-mode devices must not obstruct the SDA and SCL lines if V_{DD} is switched off.
- n/a = not applicable.

Table 2: AC Electrical Specifications for I²C Bus

Symbol	Parameter	Standard-Mode		Fast-Mode		Unit
		Min.	Max.	Min.	Max.	
f _{SCL}	SCL Clock Frequency	0	100	0	400	kHz
t _{HD:STD}	Hold Time (repeated) START Condition. After this period, the first clock pulse is generated	4.0		0.6		μs
t _{LOW}	LOW Period of the SCL Clock	4.7		1.3		μs
t _{HIGH}	HIGH Period of the SCL Clock	4.0		0.6		μs
t _{SU:STA}	Setup Time for a Repeated START Condition	4.7		0.6		μs
t _{HD:DAT}	Data Hold Time:					
	For CBUS Compatible Master	5.0	-	-	-	μs
	For I ² C Bus Devices	0 ⁽²⁾	3.45 ⁽³⁾	0 ⁽²⁾	0.9 ⁽³⁾	μs
t _{SU:DAT}	Data Setup Time	250		100 ⁽⁴⁾		ns
t _r	Rise Time of Both SDA and SCL Signals		1000	20 + 0.1C _b ⁽⁵⁾	300	ns
t _f	Fall Time of Both SDA and SCL Signals		300	20 + 0.1C _b ⁽⁵⁾	300	ns
t _{SU:STO}	Setup Time for STOP Condition	4.0		0.6		μs
t _{BUF}	Bus Free Time between a STOP and START condition	4.7		1.3		μs
C _b	Capacitive Load for each Bus Line		400		40	pF
V _{nL}	Noise margin at the LOW level for each connected device (including Hysteresis)	0.1 x V _{DD}		0.1 x V _{DD}		V
V _{nH}	Noise margin at the HIGH level for each connected device (including Hysteresis)	0.2 x V _{DD}		0.2 x V _{DD}		V

NOTE:

- All values referred to V_{IHmin} and V_{ILmax} levels (see Table 1).
- A device must internally provide a hold time of at least 300ns for the SDA signal (referred to the V_{IHmin} of the SCL signal) to bridge the undefined regions of the falling edge of SCL.
- The maximum t_{HD:DAT} has only to be met if the device does not stretch the LOW period (t_{LOW}) of the SCL signal.
- A Fast-mode I²C-bus device can be used in a Standard-mode I²C-bus system, but the requirement t_{SU:DAT} ≥ 250ns must then be met. This will automatically be the case if the device does not stretch the LOW period of the SCL signal. If such a device does stretch the LOW period of the SCL signal, it must output the next data bit to the SDA line t_{max} + t_{SU:DAT} = 1,000 + 250 = 1,250ns (according to the Standard-mode I²C-bus specifications) before the SCL line is released.
- C_b = total capacitance of one bus line in pF. If mixed with Hs-mode devices, faster fall-times according to the Table 2 are allowed.

n/a = not applicable.

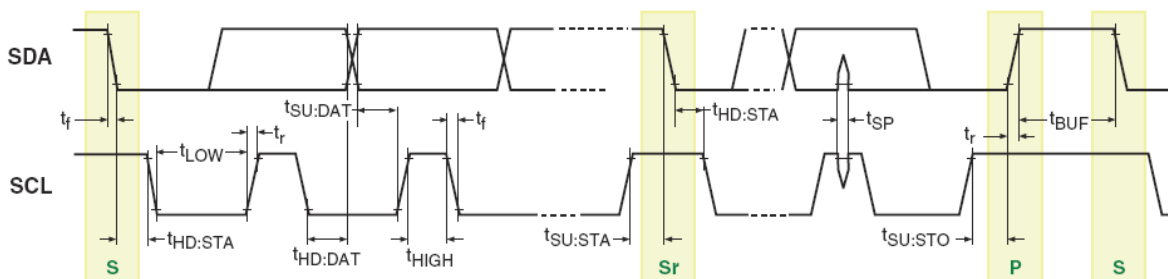
**Figure 5: Definition of Timing for F/S-mode Devices on the I²C Bus**

Application Information

32-pin Package (32QFN)

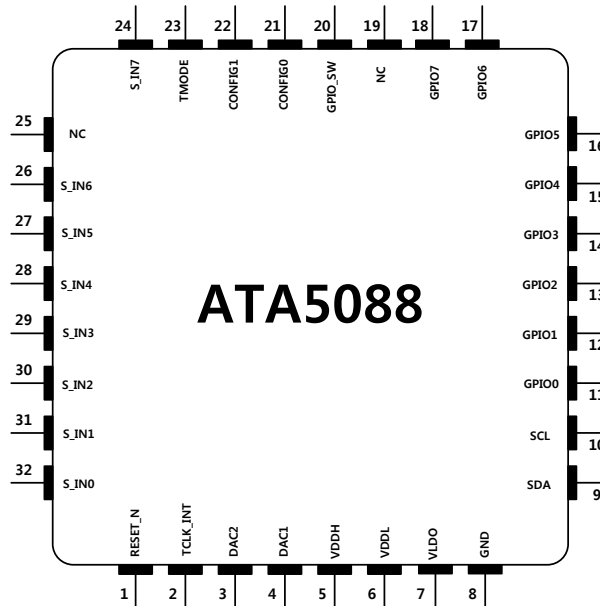

Pin Description

Name	IO	Pin #	Description															
RESET_N	I	1	Reset, active LOW															
TCLK_INT	IO	2	External Clock Input or Touch Interrupt Output(Default Output)															
S_IN	IO	24,26-32	Eight Sensor Inputs connecting Touch Pads or GPO at I ² C Mode															
GPIO	IO	11-18	Configured by HOST (Open Drain Output): - Extended GPIOs, Direct Button Outputs or External Interrupt inputs															
GPIO_SW	O	20	S_IN6 Touch output (CMOS output)															
SDA	IO	9	Bidirectional I ² C Data from/to Host															
SCL	I	10	I ² C CLK from Host															
DAC	O	3,4	DAC output for touch state(@ 3.3V VCC Condition) <table border="1"> <thead> <tr> <th>Voltage</th> <th>1.67V</th> <th>1.37V</th> <th>1.07V</th> <th>0.67V</th> </tr> </thead> <tbody> <tr> <td>DAC1</td> <td>S_IN3</td> <td>S_IN2</td> <td>S_IN1</td> <td>S_IN0</td> </tr> <tr> <td>DAC2</td> <td>S_IN7</td> <td>S_IN6</td> <td>S_IN5</td> <td>S_IN4</td> </tr> </tbody> </table>	Voltage	1.67V	1.37V	1.07V	0.67V	DAC1	S_IN3	S_IN2	S_IN1	S_IN0	DAC2	S_IN7	S_IN6	S_IN5	S_IN4
Voltage	1.67V	1.37V	1.07V	0.67V														
DAC1	S_IN3	S_IN2	S_IN1	S_IN0														
DAC2	S_IN7	S_IN6	S_IN5	S_IN4														
CONFIG	I	21, 22	MCU Control Mode or Fixed Register Mode (00: MCU Control Mode, 01: Sensitivity Low Mode-1, 10: Sensitivity Middle Mode-2, 11: Sensitivity High Mode-3) <table border="1"> <thead> <tr> <th>CONFIG 1</th> <th>0</th> <th>0</th> <th>1</th> <th>1</th> </tr> </thead> <tbody> <tr> <th>CONFIG 0</th> <td>0</td> <td>1</td> <td>0</td> <td>1</td> </tr> <tr> <th>Setting</th> <td>MCU</td> <td>Low</td> <td>Middle</td> <td>High</td> </tr> </tbody> </table>	CONFIG 1	0	0	1	1	CONFIG 0	0	1	0	1	Setting	MCU	Low	Middle	High
CONFIG 1	0	0	1	1														
CONFIG 0	0	1	0	1														
Setting	MCU	Low	Middle	High														
TMODE	I	23	Touch Output Mode Select (“L”: APIS1, “H”: APIS2)															
VDDH	P	22	Power (2.5-5.5V)															
VLDO	O	21	2.5V Regulator Power Output															
VDDL	P	20	2.5V Power Input															
GND	P	19	Ground															

32QFN Typical Application Circuit – External DAC

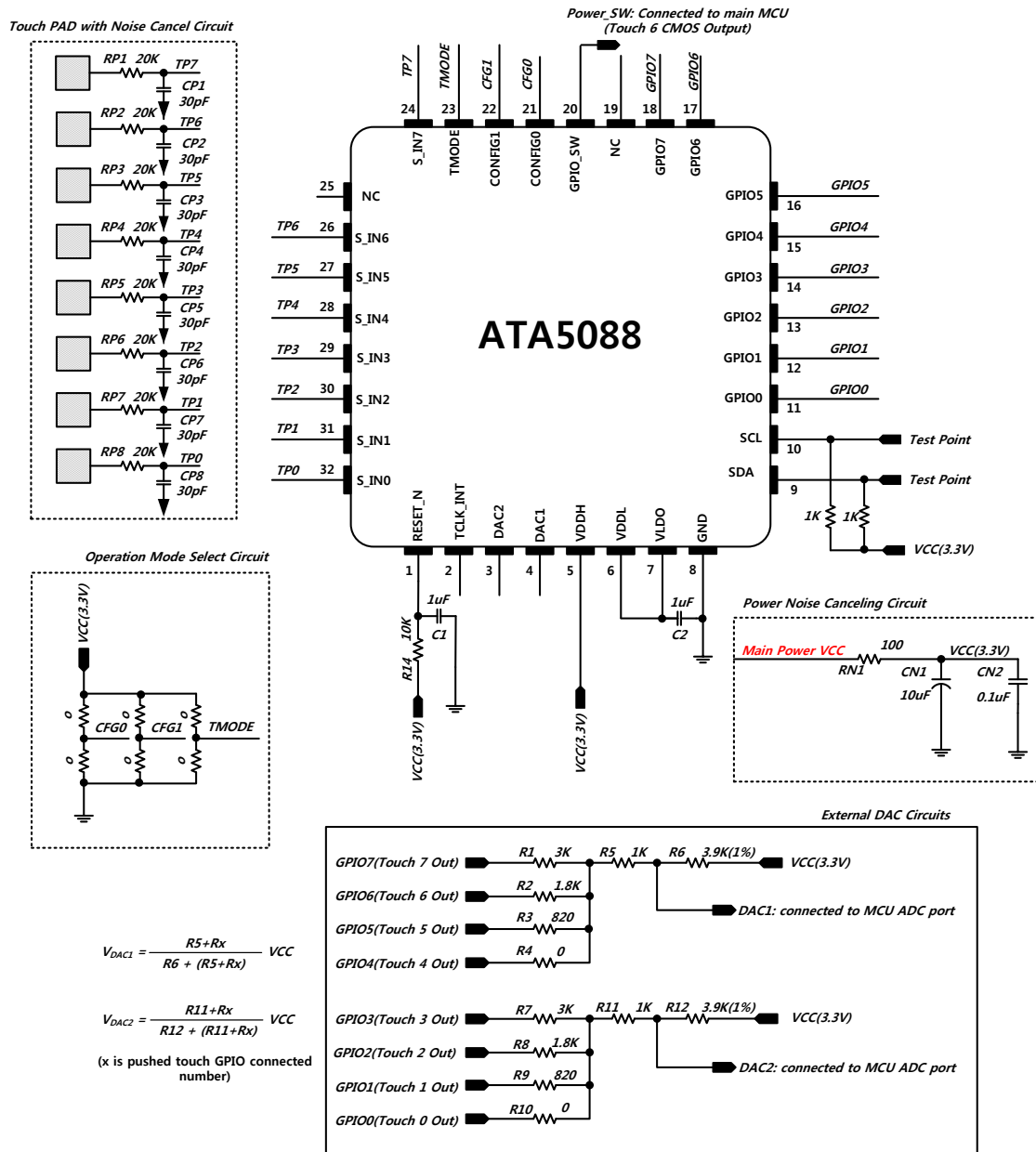

Notes:

- Pull-Up resistors are required for I²C communication. For 5V application, 2K ohm resistor is typically used. For 3V application, 1K ohm resistor is typically used.
- The circuit above is a typical application circuit using an internal LDO.
- RESET_N pin should be connected to host MCU GPIO and needs POR components.(R1=10KΩ, C1=1uF)
- GPIO's output data format is like mechanical switch output form, i.e. No touch: Open, Touch: GND.
- Other DAC output voltage range can be achieved just by modifying resistor value (R1~R12).
- Unlike typical application circuit consisting 8channel, if one uses less number of touch channels, non-assigned sensor pins are open and corresponding GPIO pins are grounded.
- To have I²C communication test points for monitoring touch sensitivity, SCL and ADA probe points are defined in the circuit(support I²C 100KHz speed).

32QFN Typical Application Circuit – Internal DAC

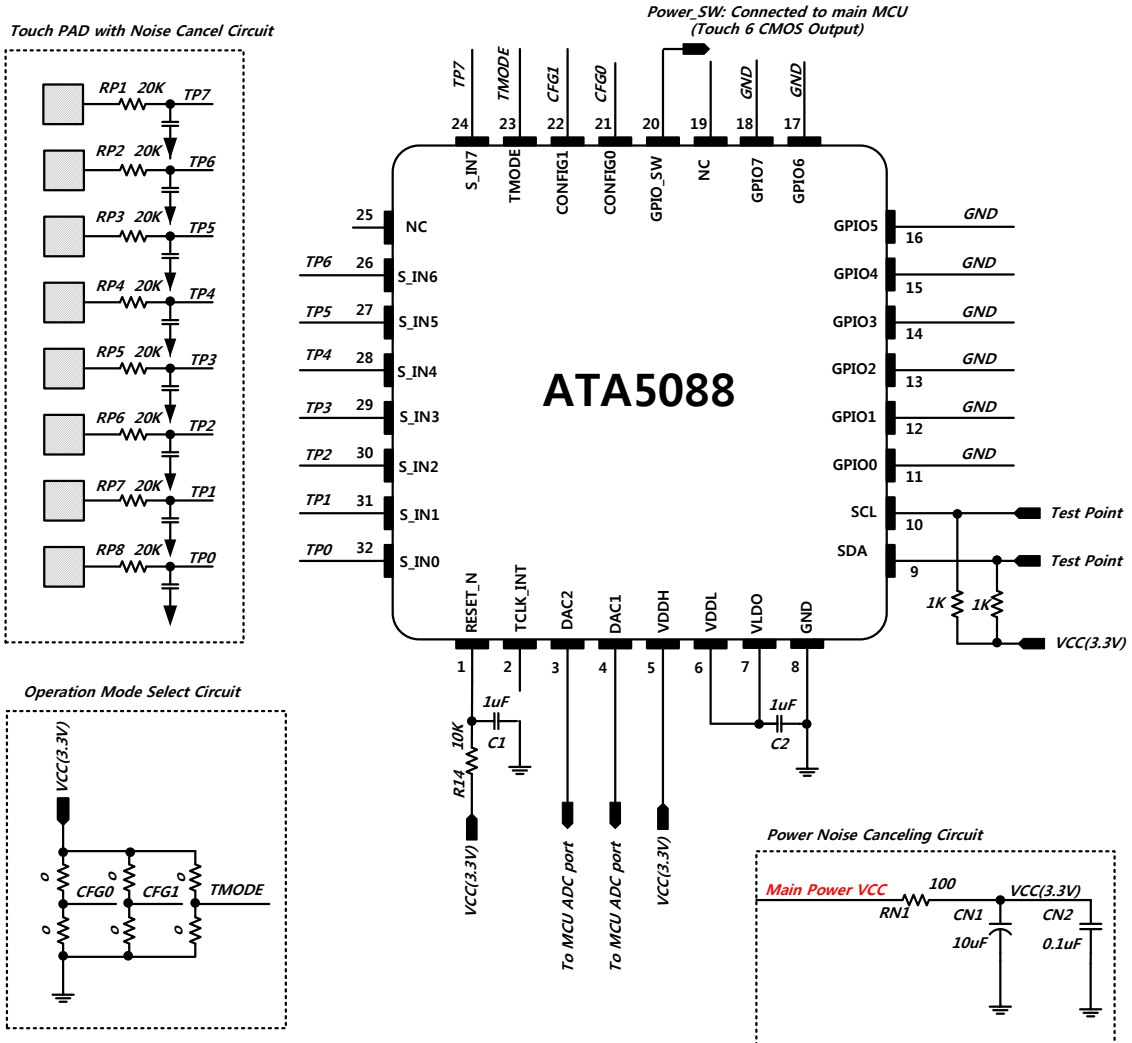

Notes:

- Pull-Up resistors are required for I²C communication. For 5V application, 1K ohm resistor is typically used. For 3V application, 2K ohm resistor is typically used.
- The circuit above is a typical application circuit using an internal LDO.
- RESET_N pin should be connected to host MCU GPIO and needs POR components.(R1=10KΩ, C1=1uF)
- GPIO's output data format is like mechanical switch output form, i.e. No touch: Open, Touch: GND.
- Unlike typical application circuit consisting 8channel, if one uses less number of touch channels, non-assigned sensor pins are open and corresponding GPIO pins are grounded.
- To have I²C communication test points for monitoring touch sensitivity, SCL and ADA probe points are defined in the circuit(support I²C 100KHz speed).

32QFN Typical Application Circuit – I²C Interface

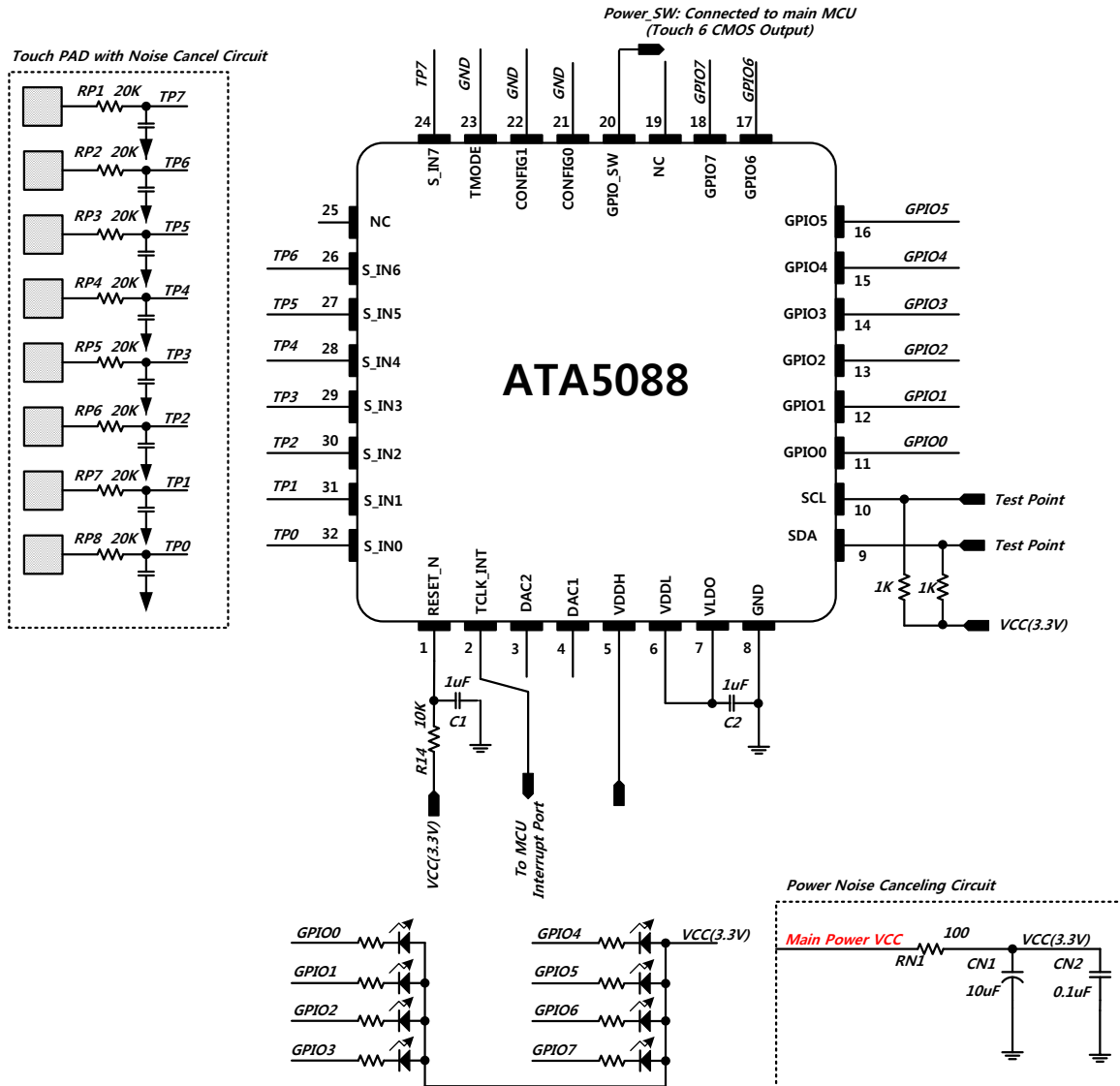

Notes:

- Pull-Up resistors are required for I²C communication. For 5V application, 1K ohm resistor is typically used. For 3V application, 2K ohm resistor is typically used.
- The circuit above is a typical application circuit using an internal LDO.
- RESET_N pin should be connected to host MCU GPIO and needs POR components.(R1=10KΩ, C1=1uF)
- GPIO's output data format is like mechanical switch output form, i.e. No touch: Open, Touch: GND.
- Unlike typical application circuit consisting 8channel, if one uses less number of touch channels, non-assigned sensor pins are open and corresponding GPIO pins are grounded.
- To have I²C communication test points for monitoring touch sensitivity, SCL and ADA probe points are defined in the circuit(support I²C 100KHz speed).

16-pin Package (16QFN)

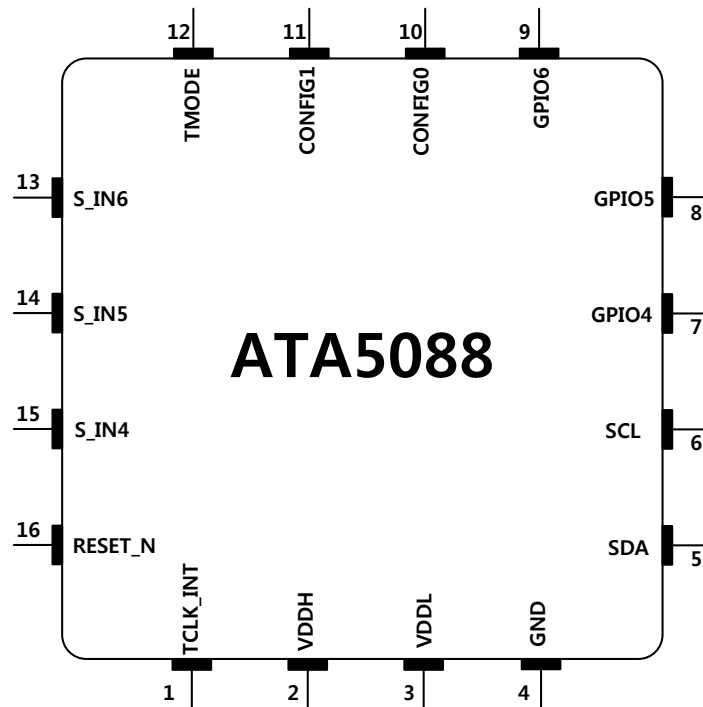

Pin Description

Name	IO	Pin #	Description															
RESET_N	I	16	Reset, active LOW															
TCLK_INT	IO	1	External Clock Input or Touch Interrupt Output(Default Output)															
S_IN	IO	13-15	Three Sensor Inputs connecting Touch Pads or GPO at I ² C Mode															
GPIO	IO	7-9	Configured by HOST (Open Drain Output): - Extended GPIOs, Direct Button Outputs or External Interrupt inputs															
SDA	IO	5	Bidirectional I ² C Data from/to Host															
SCL	I	6	I ² C CLK from Host															
CONFIG	I	10, 11	MCU Control Mode or Fixed Register Mode (00: MCU Control Mode, 01: Sensitivity Low Mode-1, 10: Sensitivity Middle Mode-2, 11: Sensitivity High Mode-3) <table border="1"> <thead> <tr> <th>CONFIG 1</th> <th>0</th> <th>0</th> <th>1</th> <th>1</th> </tr> </thead> <tbody> <tr> <td>CONFIG 0</td> <td>0</td> <td>1</td> <td>0</td> <td>1</td> </tr> <tr> <td>Setting</td> <td>MCU</td> <td>Low</td> <td>Middle</td> <td>High</td> </tr> </tbody> </table>	CONFIG 1	0	0	1	1	CONFIG 0	0	1	0	1	Setting	MCU	Low	Middle	High
CONFIG 1	0	0	1	1														
CONFIG 0	0	1	0	1														
Setting	MCU	Low	Middle	High														
TMODE	I	12	Touch Output Mode Select (“L”: APIS1, “H”: APIS2)															
VDDH	P	2	Power (2.5-5.5V)															
VDDL	P	3	2.5V Power Input for Core Circuit															
GND	P	4	Ground															

*16 pins package does not support the internal DAC output mode.

16QFN Typical Application Circuit – External DAC

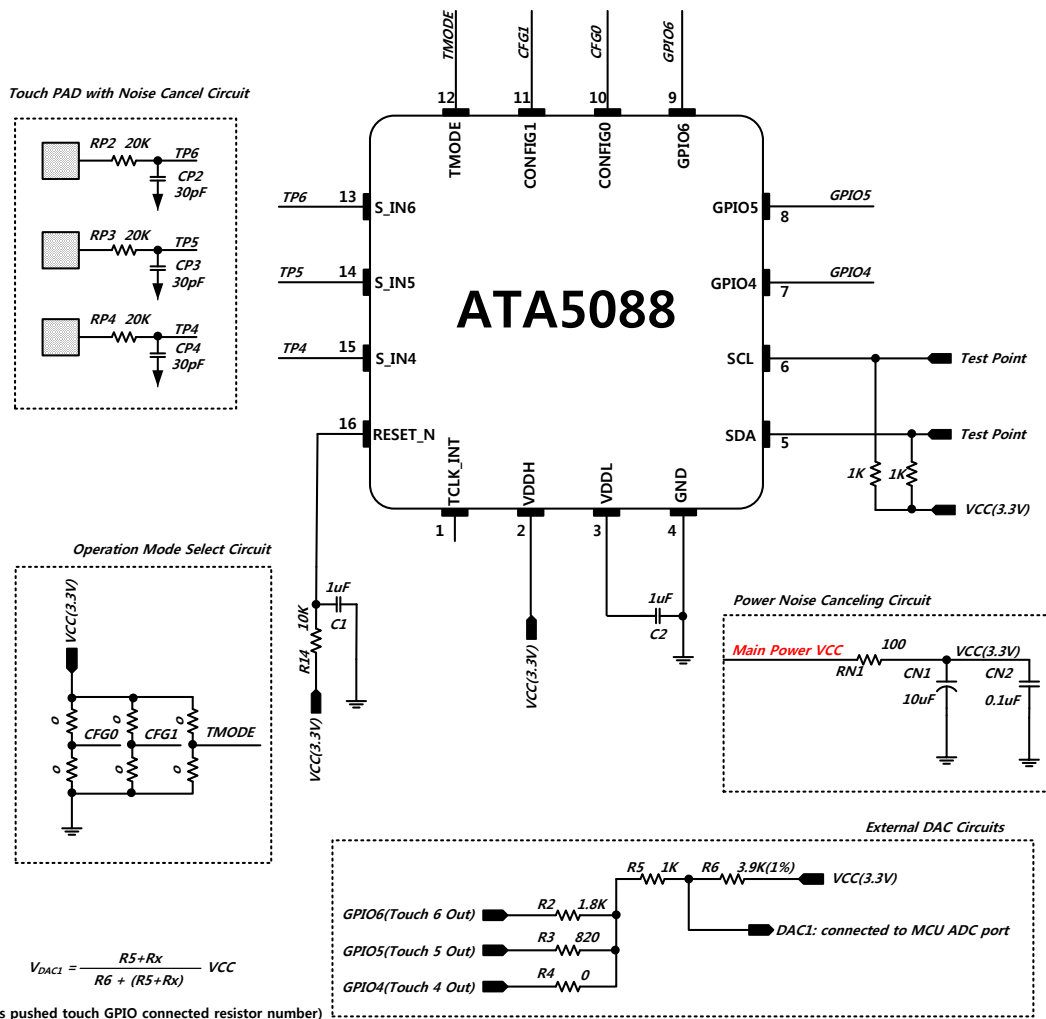

Notes:

- Pull-Up resistors are required for I²C communication. For 5V application, 2K ohm resistor is typically used. For 3V application, 1K ohm resistor is typically used.
- The circuit above is a typical application circuit using an internal LDO.
- RESET_N pin should be connected to host MCU GPIO and needs POR components.(R1=10KΩ, C1=1uF)
- GPIO's output data format is like mechanical switch output form, i.e. No touch: Open, Touch: GND.
- Other DAC output voltage range can be achieved just by modifying resistor value (R4~R6).
- Unlike typical application circuit consisting 8channel, if one uses less number of touch channels, non-assigned sensor pins are open and corresponding GPIO pins are grounded.
- To have I²C communication test points for monitoring touch sensitivity, SCL and ADA probe points are defined in the circuit(support I²C 100KHz speed).

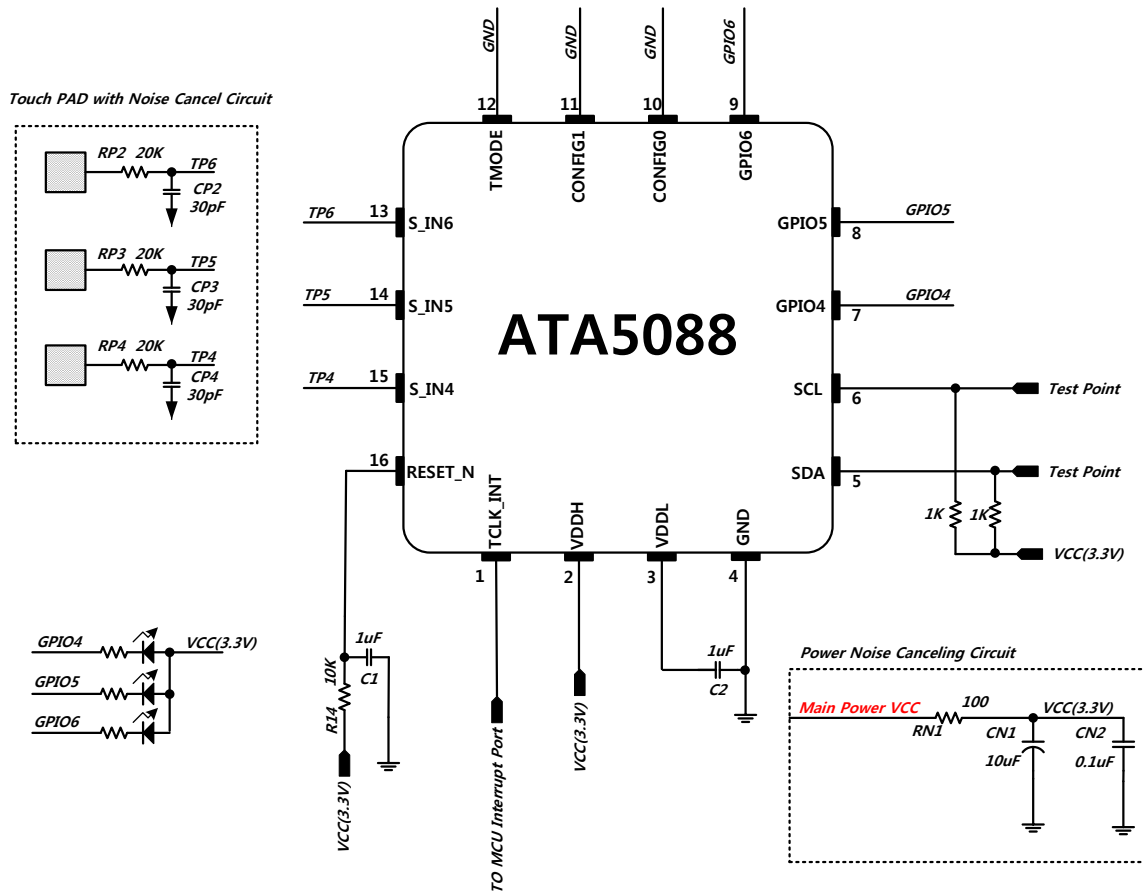
16QFN Typical Application Circuit – I²C Interface**Notes:**

- Pull-Up resistors are required for I²C communication. For 5V application, 1K ohm resistor is typically used. For 3V application, 2K ohm resistor is typically used.
- The circuit above is a typical application circuit using an internal LDO.
- RESET_N pin should be connected to host MCU GPIO and needs POR components.(R1=10KΩ, C1=1uF)
- GPIO's output data format is like mechanical switch output form, i.e. No touch: Open, Touch: GND.
- Unlike typical application circuit consisting 8channel, if one uses less number of touch channels, non-assigned sensor pins are open and corresponding GPIO pins are grounded.
- To have I²C communication test points for monitoring touch sensitivity, SCL and ADA probe points are defined in the circuit(support I²C 100KHz speed).

30-pin Package (30SSOP)

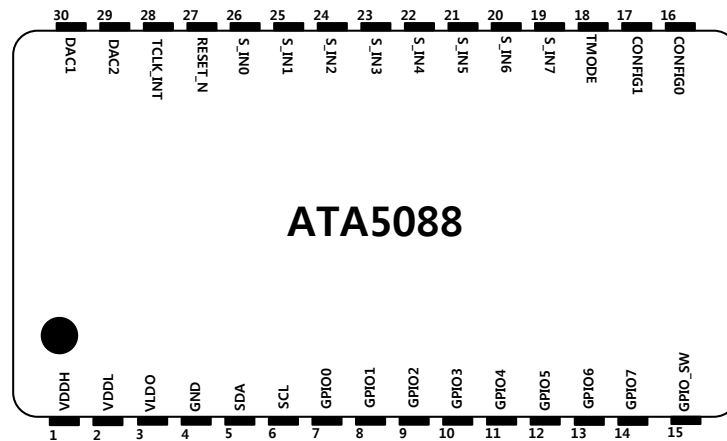

Pin Description

Name	IO	Pin #	Description															
RESET_N	I	27	Reset, active LOW															
TCLK_INT	IO	28	External Clock Input or Touch Interrupt Output(Default Output)															
S_IN	IO	19-26	Eight Sensor Inputs connecting Touch Pads or GPO at I ² C Mode															
GPIO	IO	7-14	Configured by HOST (Open Drain Output): - Extended GPIOs, Direct Button Outputs or External Interrupt inputs															
GPIO_SW	O	15	S_IN6 Touch output (CMOS output)															
SDA	IO	5	Bidirectional I ² C Data from/to Host															
SCL	I	6	I ² C CLK from Host															
DAC	O	29, 30	DAC output for touch state(@ 3.3V VCC Condition) <table border="1"> <thead> <tr> <th>Voltage</th> <th>1.67V</th> <th>1.37V</th> <th>1.07V</th> <th>0.67V</th> </tr> </thead> <tbody> <tr> <td>DAC1</td> <td>S_IN3</td> <td>S_IN2</td> <td>S_IN1</td> <td>S_IN0</td> </tr> <tr> <td>DAC2</td> <td>S_IN7</td> <td>S_IN6</td> <td>S_IN5</td> <td>S_IN4</td> </tr> </tbody> </table>	Voltage	1.67V	1.37V	1.07V	0.67V	DAC1	S_IN3	S_IN2	S_IN1	S_IN0	DAC2	S_IN7	S_IN6	S_IN5	S_IN4
Voltage	1.67V	1.37V	1.07V	0.67V														
DAC1	S_IN3	S_IN2	S_IN1	S_IN0														
DAC2	S_IN7	S_IN6	S_IN5	S_IN4														
CONFIG	I	16, 17	MCU Control Mode or Fixed Register Mode (00: MCU Control Mode, 01: Sensitivity Low Mode-1, 10: Sensitivity Middle Mode-2, 11: Sensitivity High Mode-3) <table border="1"> <thead> <tr> <th>CONFIG 1</th> <th>0</th> <th>0</th> <th>1</th> <th>1</th> </tr> </thead> <tbody> <tr> <th>CONFIG 0</th> <th>0</th> <th>1</th> <th>0</th> <th>1</th> </tr> <tr> <th>Setting</th> <th>MCU</th> <th>Low</th> <th>Middle</th> <th>High</th> </tr> </tbody> </table>	CONFIG 1	0	0	1	1	CONFIG 0	0	1	0	1	Setting	MCU	Low	Middle	High
CONFIG 1	0	0	1	1														
CONFIG 0	0	1	0	1														
Setting	MCU	Low	Middle	High														
TMODE	I	18	Touch Output Mode Select (“L”: APIS1, “H”: APIS2)															
VDDH	P	1	Power (2.5-5.5V)															
VLDO	O	3	2.5V Regulator Power Output															
VDDL	P	2	2.5V Power Input															
GND	P	4	Ground															

30SSOP Typical Application Circuit – External DAC

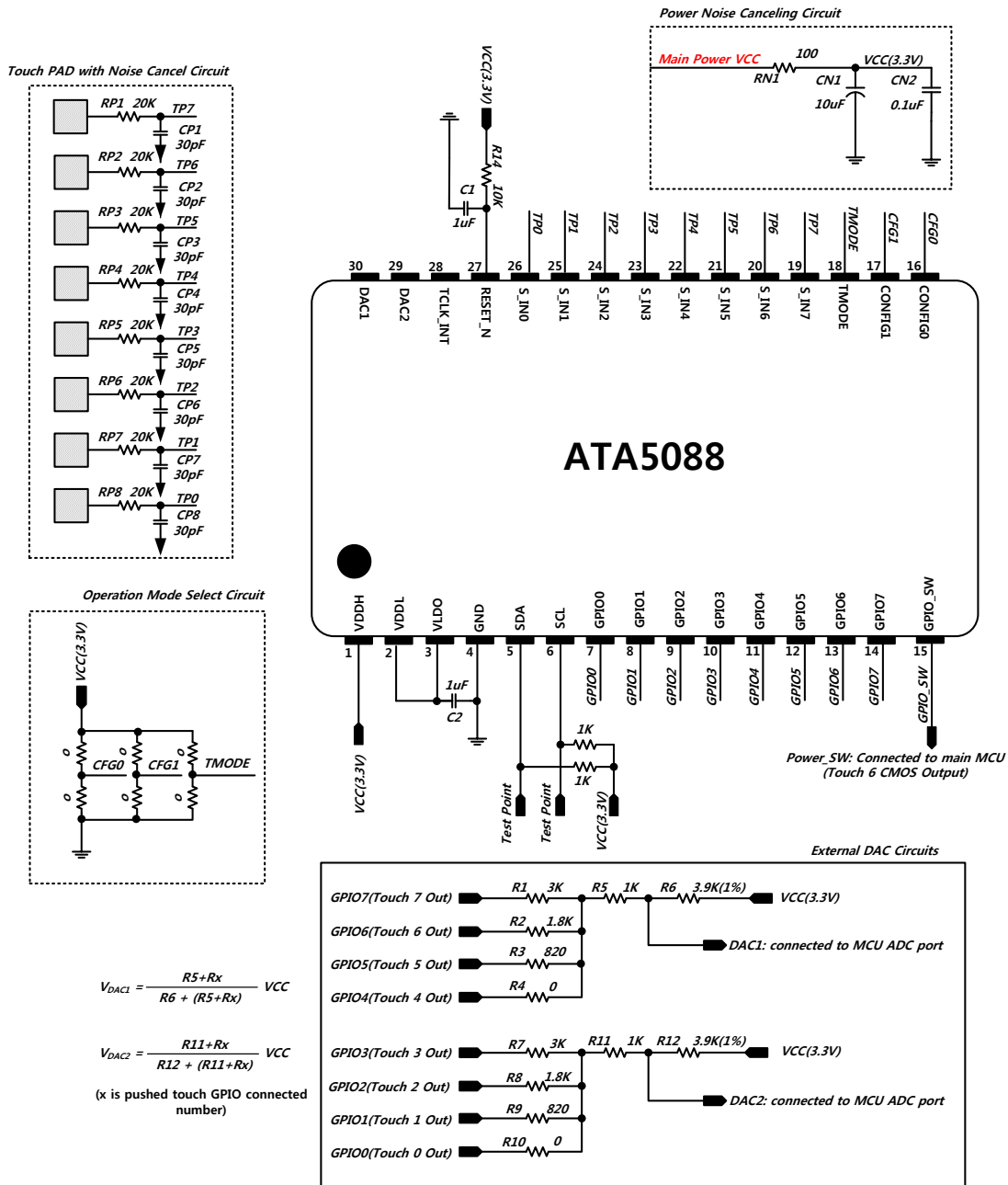

$$V_{DAC1} = \frac{R5 + Rx}{R6 + (R5 + Rx)} VCC$$

$$V_{DAC2} = \frac{R11 + Rx}{R12 + (R11 + Rx)} VCC$$

(x is pushed touch GPIO connected number)

Notes:

- Pull-Up resistors are required for I²C communication. For 5V application, 2K ohm resistor is typically used. For 3V application, 1K ohm resistor is typically used.
- The circuit above is a typical application circuit using an internal LDO.
- RESET_N pin should be connected to host MCU GPIO and needs POR components.(R1=10KΩ, C1=1uF)
- GPIO's output data format is like mechanical switch output form, i.e. No touch: Open, Touch: GND.
- Other DAC output voltage range can be achieved just by modifying resistor value (R1~R12).
- Unlike typical application circuit consisting 8channel, if one uses less number of touch channels, non-assigned sensor pins are open and corresponding GPIO pins are grounded.
- To have I²C communication test points for monitoring touch sensitivity, SCL and ADA probe points are defined in the circuit(support I²C 100KHz speed).

30SSOP Typical Application Circuit – Internal DAC

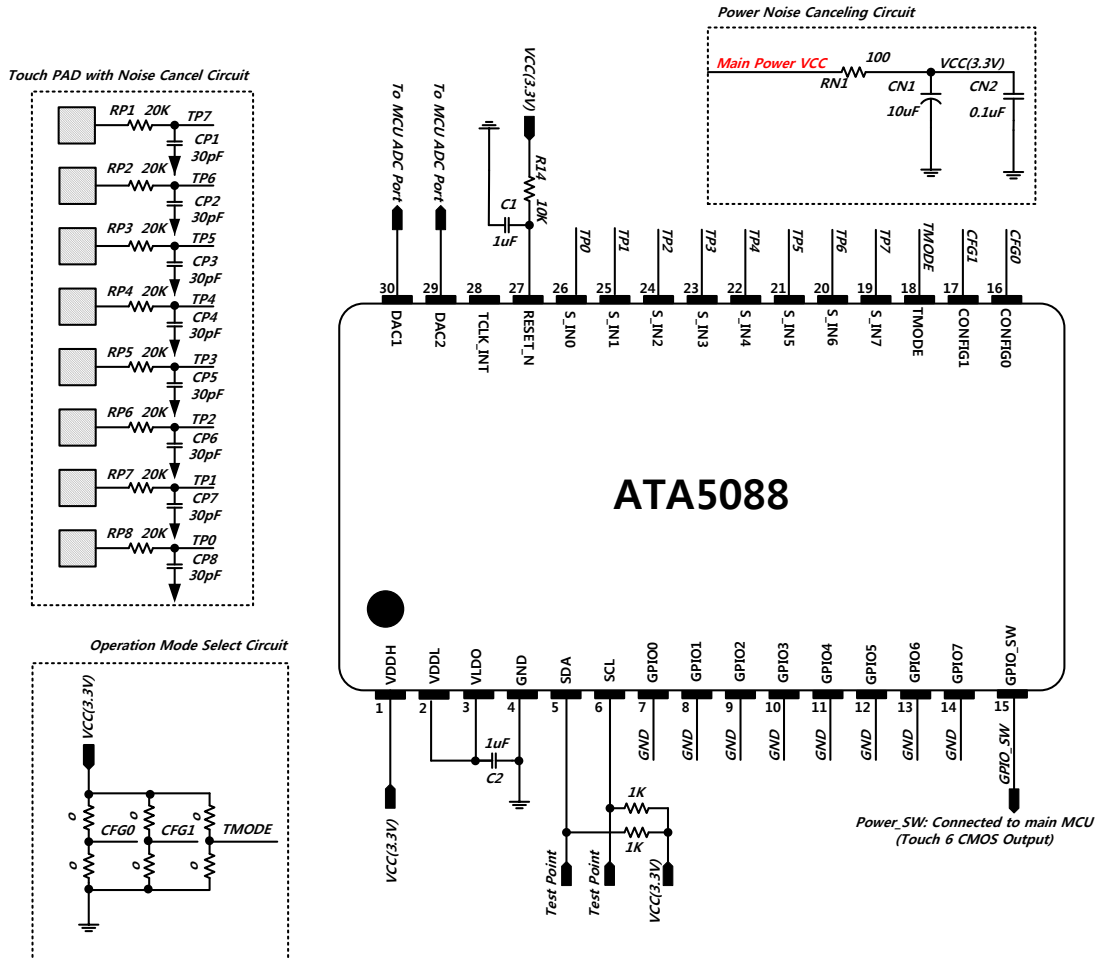

Notes:

- Pull-Up resistors are required for I²C communication. For 5V application, 1K ohm resistor is typically used. For 3V application, 2K ohm resistor is typically used.
- The circuit above is a typical application circuit using an internal LDO.
- RESET_N pin should be connected to host MCU GPIO and needs POR components.(R1=10KΩ, C1=1uF)
- GPIO's output data format is like mechanical switch output form, i.e. No touch: Open, Touch: GND.
- Unlike typical application circuit consisting 8channel, if one uses less number of touch channels, non-assigned sensor pins are open and corresponding GPIO pins are grounded.
- To have I²C communication test points for monitoring touch sensitivity, SCL and ADA probe points are defined in the circuit(support I²C 100KHz speed).

30SSOP Typical Application Circuit – I²C Interface

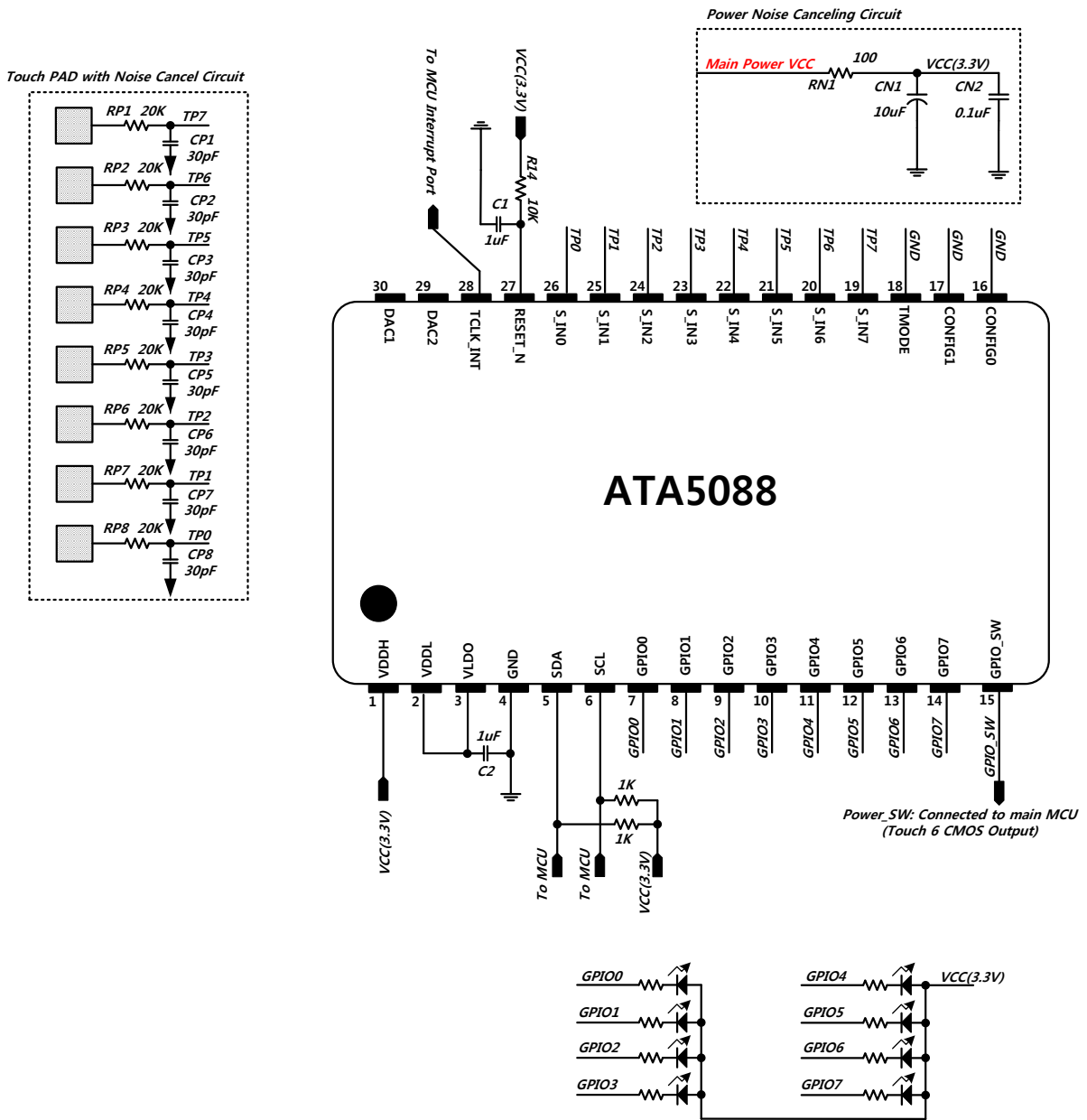

Notes:

- Pull-Up resistors are required for I²C communication. For 5V application, 1K ohm resistor is typically used. For 3V application, 2K ohm resistor is typically used.
- The circuit above is a typical application circuit using an internal LDO.
- RESET_N pin should be connected to host MCU GPIO and needs POR components.(R1=10KΩ, C1=1uF)
- GPIO's output data format is like mechanical switch output form, i.e. No touch: Open, Touch: GND.
- Unlike typical application circuit consisting 8channel, if one uses less number of touch channels, non-assigned sensor pins are open and corresponding GPIO pins are grounded.
- To have I²C communication test points for monitoring touch sensitivity, SCL and ADA probe points are defined in the circuit(support I²C 100KHz speed).

24-pin Package (24SSOP)

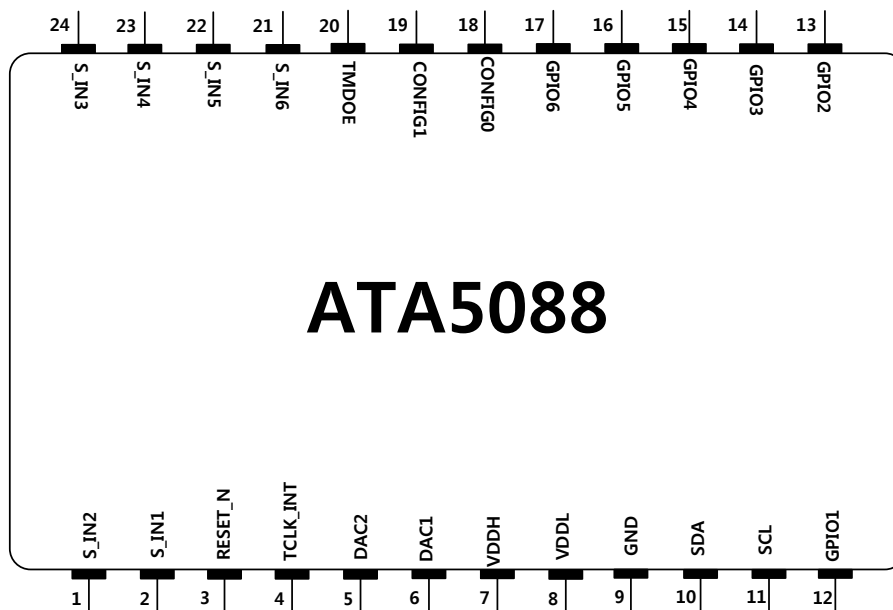

Pin Description

Name	IO	Pin #	Description																								
RESET_N	I	3	Reset, active LOW																								
TCLK_INT	IO	4	External Clock Input or Touch Interrupt output(Default Output)																								
S_IN	IO	1-2,21-24	Six Sensor Inputs connecting Touch Pads or GPO																								
GPIO	IO	12-17	Configured by HOST: - Extended GPIOs, Direct Button Outputs or External Interrupt inputs																								
SDA	IO	10	Bidirectional I ² C Data from/to Host																								
SCL	I	11	I ² C CLK from Host																								
DAC	O	5, 6	DAC output for touch state(@ 3.3V VCC Condition) <table border="1"> <thead> <tr> <th>Voltage</th> <th>1.67V</th> <th>1.37V</th> <th>1.07V</th> <th>0.67V</th> </tr> </thead> <tbody> <tr> <td>DAC1</td> <td>S_IN3</td> <td>S_IN2</td> <td>S_IN1</td> <td>S_IN0</td> </tr> <tr> <td>DAC2</td> <td>S_IN7</td> <td>S_IN6</td> <td>S_IN5</td> <td>S_IN4</td> </tr> </tbody> </table>	Voltage	1.67V	1.37V	1.07V	0.67V	DAC1	S_IN3	S_IN2	S_IN1	S_IN0	DAC2	S_IN7	S_IN6	S_IN5	S_IN4									
Voltage	1.67V	1.37V	1.07V	0.67V																							
DAC1	S_IN3	S_IN2	S_IN1	S_IN0																							
DAC2	S_IN7	S_IN6	S_IN5	S_IN4																							
CONFIG	I	18,19	MCU Control Mode or Fixed Register Mode (00: MCU Control Mode, 01: Sensitivity Low Mode-1, 10: Sensitivity Middle Mode-2, 11: Sensitivity High Mode-3) <table border="1"> <thead> <tr> <th>CONFIG</th> <th>1</th> <th>0</th> <th>0</th> <th>1</th> <th>1</th> </tr> </thead> <tbody> <tr> <td>CONFIG 1</td> <td>0</td> <td>0</td> <td>1</td> <td>1</td> <td></td> </tr> <tr> <td>CONFIG 0</td> <td>0</td> <td>1</td> <td>0</td> <td>1</td> <td></td> </tr> <tr> <td>Setting</td> <td>MCU</td> <td>Low</td> <td>Middle</td> <td>High</td> <td></td> </tr> </tbody> </table>	CONFIG	1	0	0	1	1	CONFIG 1	0	0	1	1		CONFIG 0	0	1	0	1		Setting	MCU	Low	Middle	High	
CONFIG	1	0	0	1	1																						
CONFIG 1	0	0	1	1																							
CONFIG 0	0	1	0	1																							
Setting	MCU	Low	Middle	High																							
TMODE	I	20	Touch Output Mode Select (“L”: APIS1, “H”: APIS2)																								
VDDH	P	7	Power (2.5-5.5V)																								
VDDL	P	8	2.5V Power Input for Core Circuit																								
GND	P	9	Ground																								

24SSOP Typical Application Circuit – External DAC

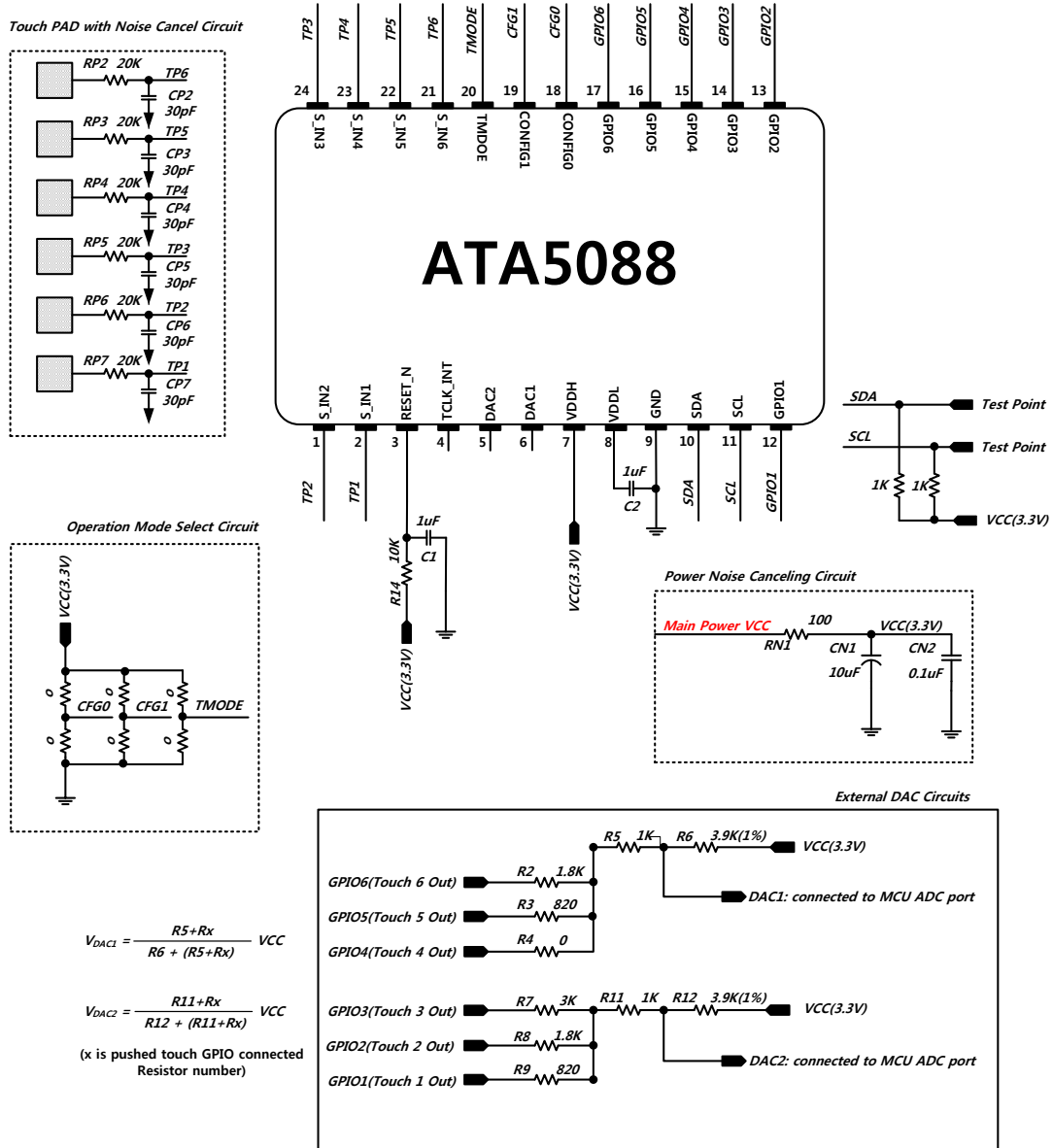

Notes:

- Pull-Up resistors are required for I²C communication. For 5V application, 2K ohm resistor is typically used. For 3V application, 1K ohm resistor is typically used.
- The circuit above is a typical application circuit using an internal LDO.
- RESET_N pin should be connected to host MCU GPIO and needs POR components.(R1=10KΩ, C1=1uF)
- GPIO's output data format is like mechanical switch output form, i.e. No touch: Open, Touch: GND.
- Other DAC output voltage range can be achieved just by modifying resistor value (R2~R12).
- Unlike typical application circuit consisting 8channel, if one uses less number of touch channels, non-assigned sensor pins are open and corresponding GPIO pins are grounded.
- To have I²C communication test points for monitoring touch sensitivity, SCL and ADA probe points are defined in the circuit(support I²C 100KHz speed).

24SSOP Typical Application Circuit – Internal DAC

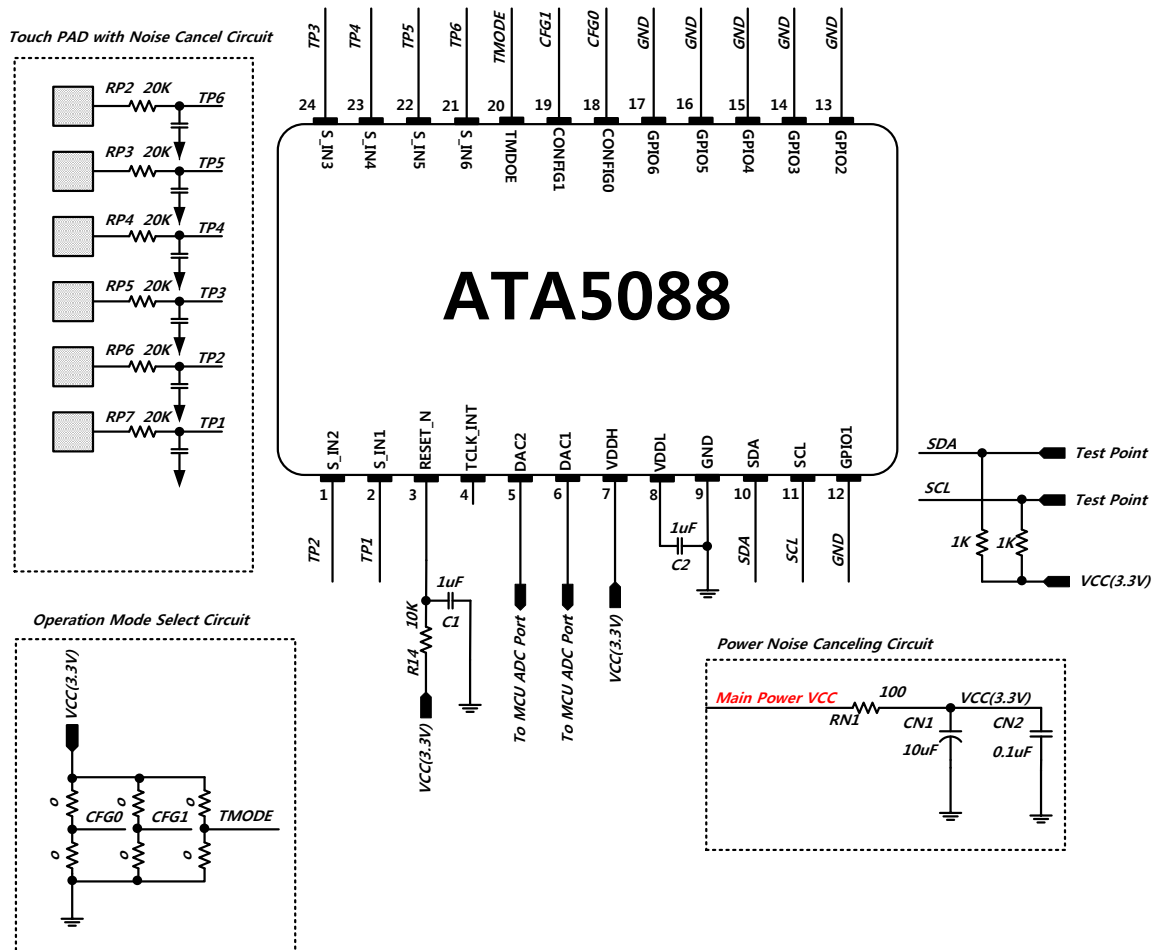

Notes:

- Pull-Up resistors are required for I²C communication. For 5V application, 1K ohm resistor is typically used. For 3V application, 2K ohm resistor is typically used.
- The circuit above is a typical application circuit using an internal LDO.
- RESET_N pin should be connected to host MCU GPIO and needs POR components.(R1=10KΩ, C1=1uF)
- GPIO's output data format is like mechanical switch output form, i.e. No touch: Open, Touch: GND.
- Unlike typical application circuit consisting 8channel, if one uses less number of touch channels, non-assigned sensor pins are open and corresponding GPIO pins are grounded.
- To have I²C communication test points for monitoring touch sensitivity, SCL and ADA probe points are defined in the circuit(support I²C 100KHz speed).

24SSOP Typical Application Circuit – I²C Interface

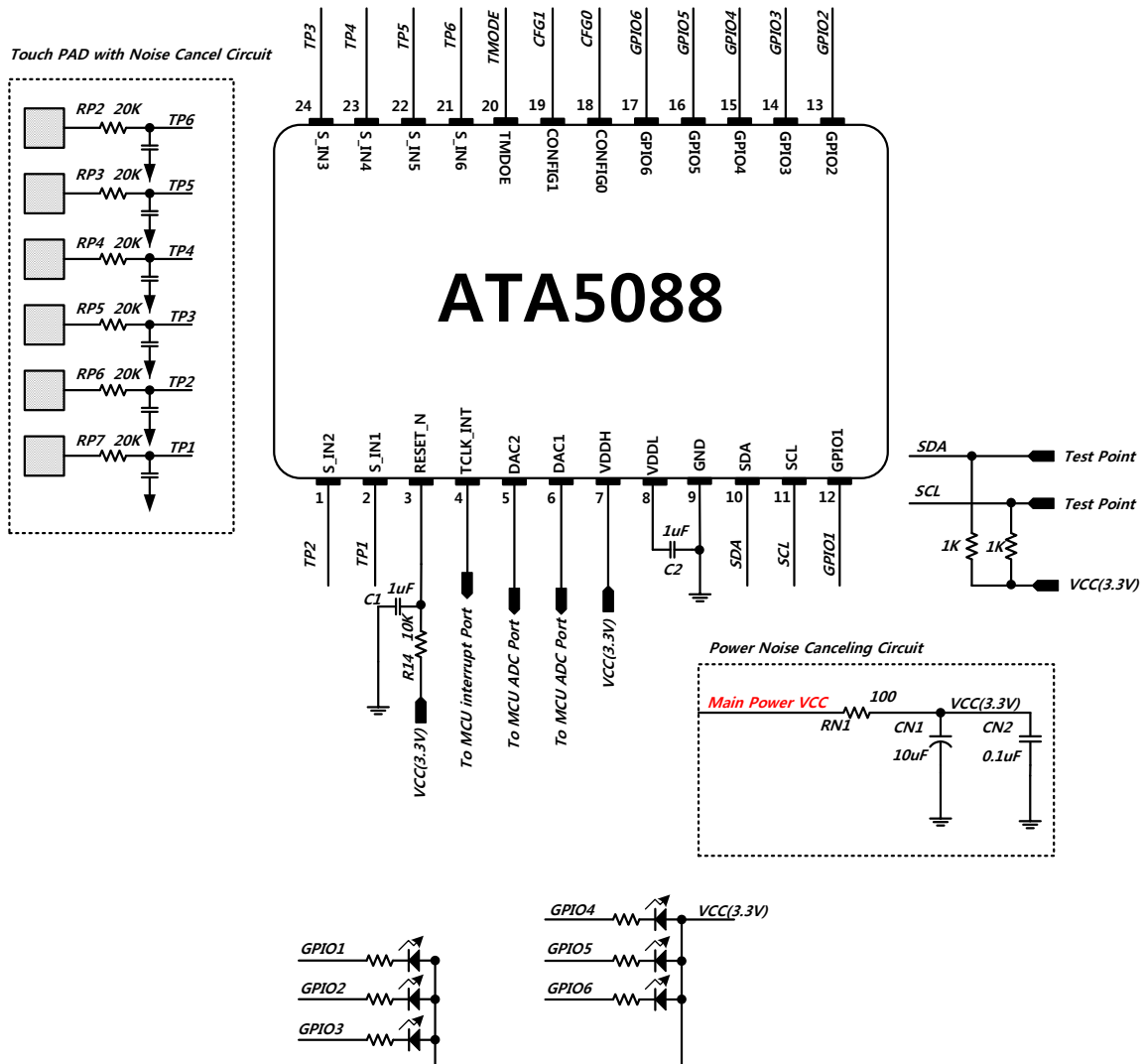

Notes:

- Pull-Up resistors are required for I²C communication. For 5V application, 1K ohm resistor is typically used. For 3V application, 2K ohm resistor is typically used.
- The circuit above is a typical application circuit using an internal LDO.
- RESET_N pin should be connected to host MCU GPIO and needs POR components.(R1=10KΩ, C1=1uF)
- GPIO's output data format is like mechanical switch output form, i.e. No touch: Open, Touch: GND.
- Unlike typical application circuit consisting 8channel, if one uses less number of touch channels, non-assigned sensor pins are open and corresponding GPIO pins are grounded.
- To have I²C communication test points for monitoring touch sensitivity, SCL and ADA probe points are defined in the circuit(support I²C 100KHz speed).

16-pin Package (16SOP)

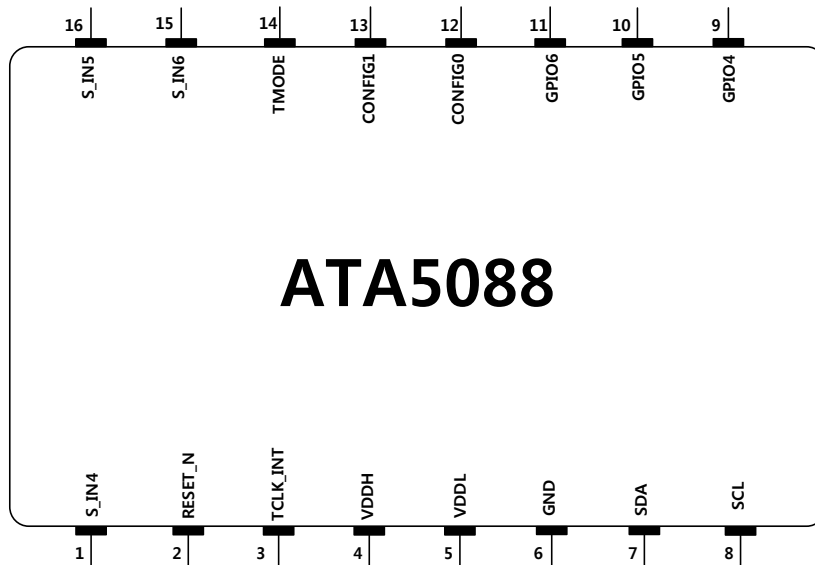

Pin Description

Name	IO	Pin #	Description																				
RESET_N	I	2	Reset, active LOW																				
TCLK_INT	IO	3	External Clock Input or Touch Interrupt Output(Default Output)																				
S_IN	IO	1,15-16	Three Sensor Inputs connecting Touch Pads or GPO at I ² C mode																				
GPIO	IO	9-11	Configured by HOST: - Extended GPIOs, Direct Button Outputs or External Interrupt inputs																				
SDA	IO	7	Bidirectional I ² C Data from/to Host																				
SCL	I	8	I ² C CLK from Host																				
CONFIG	I	12 13	MCU Control Mode or Fixed Register Mode (00: MCU Control Mode, 01: Sensitivity Low Mode-1, 10: Sensitivity Middle Mode-2, 11: Sensitivity High Mode-3) <table border="1" style="margin-left: 20px;"> <thead> <tr> <th>CONFIG</th> <th>1</th> <th>0</th> <th>1</th> <th>1</th> </tr> </thead> <tbody> <tr> <td>CONFIG 1</td> <td>0</td> <td>0</td> <td>1</td> <td>1</td> </tr> <tr> <td>CONFIG 0</td> <td>0</td> <td>1</td> <td>0</td> <td>1</td> </tr> <tr> <td>Setting</td> <td>MCU</td> <td>Low</td> <td>Middle</td> <td>High</td> </tr> </tbody> </table>	CONFIG	1	0	1	1	CONFIG 1	0	0	1	1	CONFIG 0	0	1	0	1	Setting	MCU	Low	Middle	High
CONFIG	1	0	1	1																			
CONFIG 1	0	0	1	1																			
CONFIG 0	0	1	0	1																			
Setting	MCU	Low	Middle	High																			
TMODE	I	14	Touch Output Mode Select (“L”: APIS1, “H”: APIS2)																				
VDDH	P	4	Power (2.5-5.5V)																				
VDDL	P	5	2.5V Power Input for Core Circuit																				
GND	P	6	Ground																				

*16 pins package does not support the internal DAC output mode.

16SOP Typical Application Circuit – External DAC

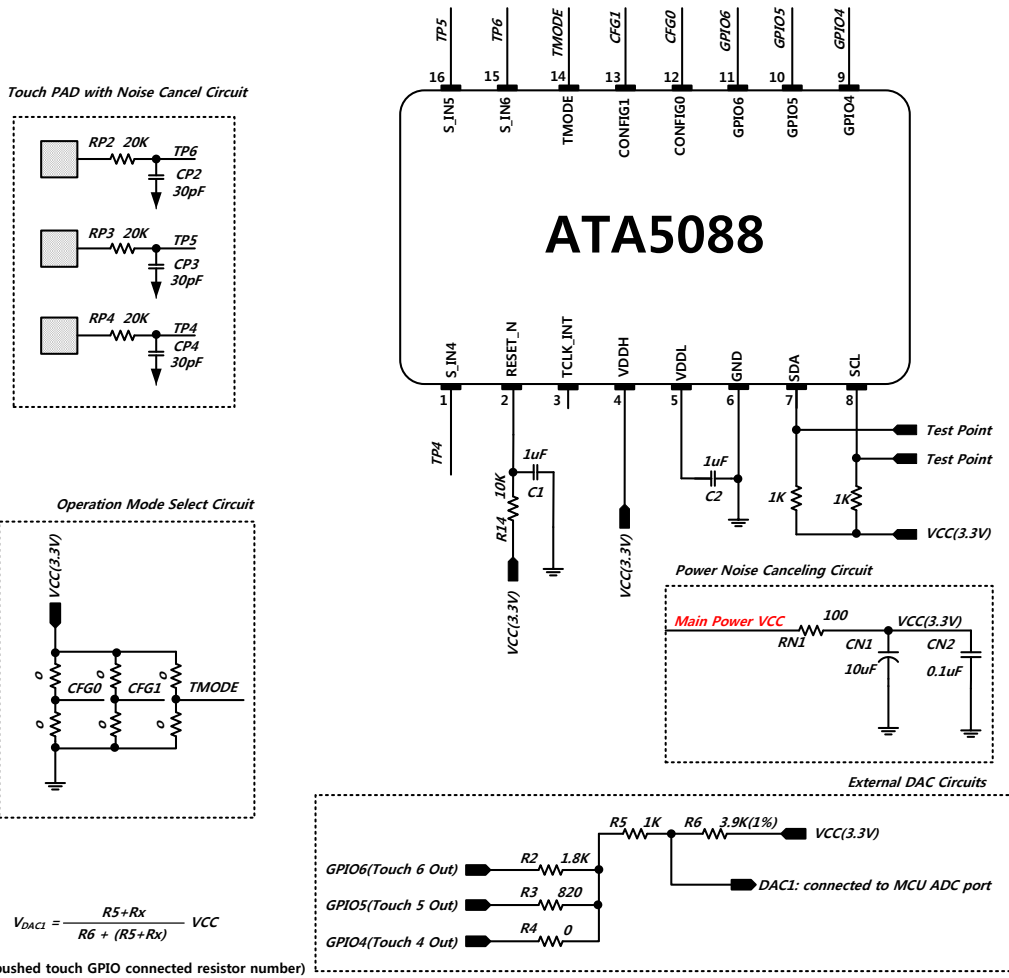

Notes:

- Pull-Up resistors are required for I²C communication. For 5V application, 2K ohm resistor is typically used. For 3V application, 1K ohm resistor is typically used.
- The circuit above is a typical application circuit using an internal LDO.
- RESET_N pin should be connected to host MCU GPIO and needs POR components.(R1=10KΩ, C1=1uF)
- GPIO's output data format is like mechanical switch output form, i.e. No touch: Open, Touch: GND.
- Other DAC output voltage range can be achieved just by modifying resistor value (R2~R6).
- Unlike typical application circuit consisting 8channel, if one uses less number of touch channels, non-assigned sensor pins are open and corresponding GPIO pins are grounded.
- To have I²C communication test points for monitoring touch sensitivity, SCL and ADA probe points are defined in the circuit(support I²C 100KHz speed).

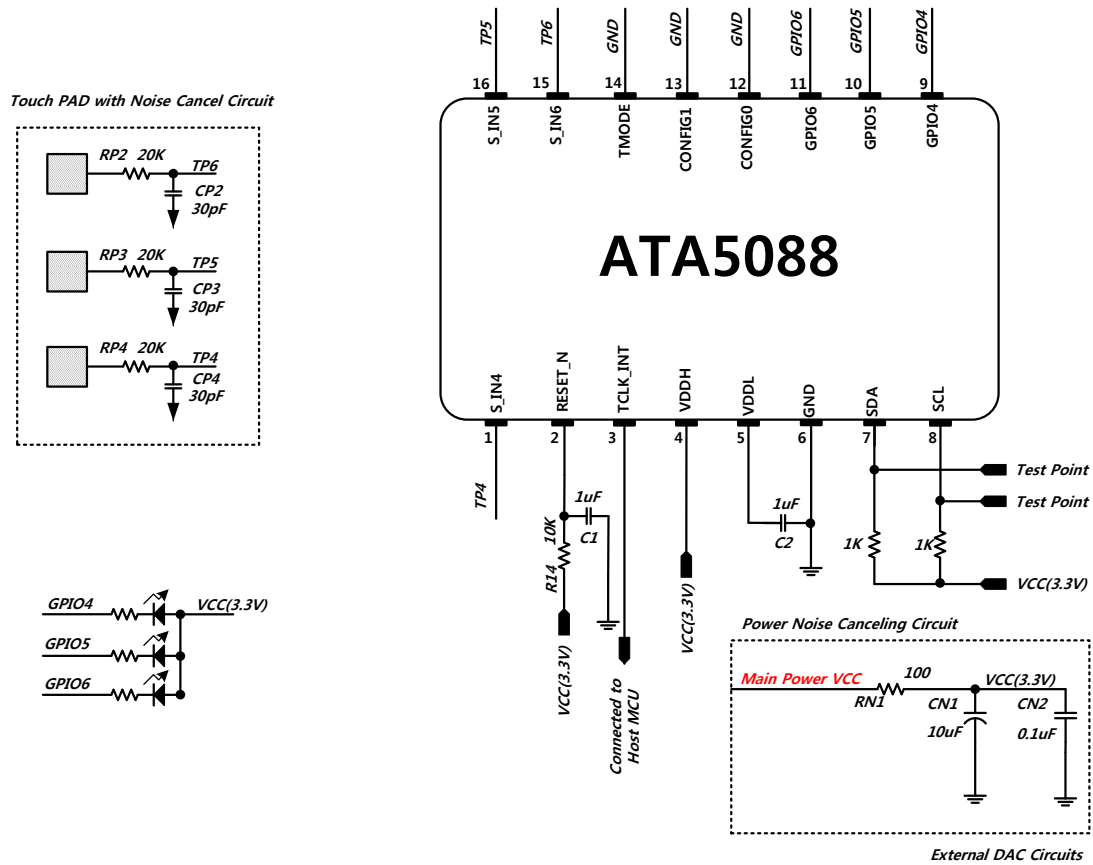
16SOP Typical Application Circuit – I²C Interface**Notes:**

- Pull-Up resistors are required for I²C communication. For 5V application, 1K ohm resistor is typically used. For 3V application, 2K ohm resistor is typically used.
- The circuit above is a typical application circuit using an internal LDO.
- RESET_N pin should be connected to host MCU GPIO and needs POR components.(R1=10KΩ, C1=1uF)
- GPIO's output data format is like mechanical switch output form, i.e. No touch: Open, Touch: GND.
- Unlike typical application circuit consisting 8channel, if one uses less number of touch channels, non-assigned sensor pins are open and corresponding GPIO pins are grounded.
- To have I²C communication test points for monitoring touch sensitivity, SCL and ADA probe points are defined in the circuit(support I²C 100KHz speed).

Power Connections

There are two methods to supply power to ATA5088. One is to receive V25 core voltage from internal LDO and the other is to receive core voltage from external power supply. In case of using the internal LDO, the LDO should be turned on in Sleep mode and hence it will cause slightly higher power consumption than using an external power supply for V25 core voltage.

Note that in case E below, if VPH receives 2.5V, the internal LDO cannot be used because VLDO cannot output 2.5V when VPH receives 2.5V from the external source.

Case A.

VDDH: External 5V
VLDO: External 2.5V

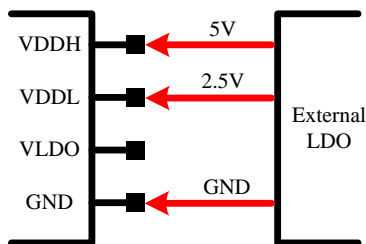

Case B.

VDDH: External 5V
VLDO: Internal LDO 2.5V

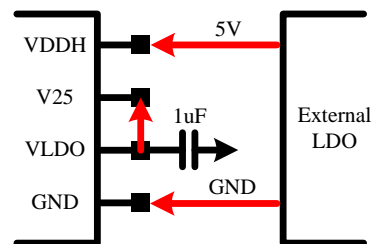

Case C.

VDDH: External 3.3V
VLDO: External 2.5V (Internal LDO off: Register Control)

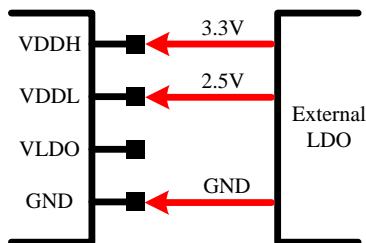

Case D.

VDDH: External 3.3V
VLDO: Internal LDO 2.5V

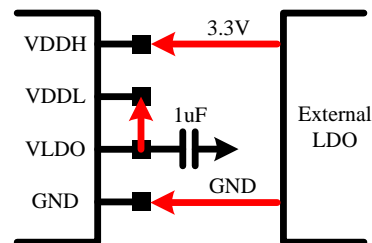

Case E.

VDDH: External 2.5V
VLDO: External 2.5V

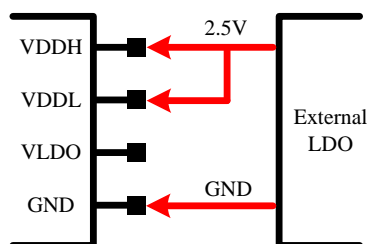

Power Sequence

To initialize the ATA5088 properly, please refer to the Power Sequence below when the power is given initially during boot-up.

If the reset transition time during power on does not follow the time sequence below, the Internal LDO and oscillator would not operate normally.

The Power Sequence is shown below when Power Connection type is Case B and Case D

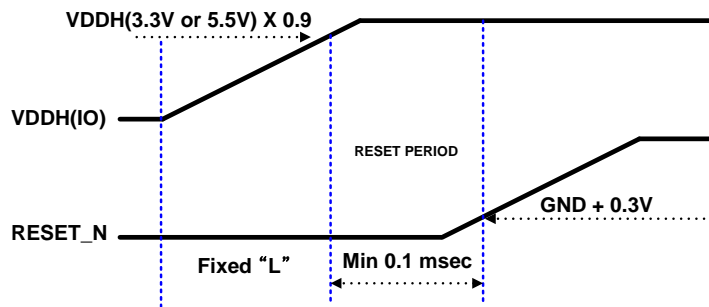

The Power Sequence is shown below when Connection type is Case A, Case C, and Case E

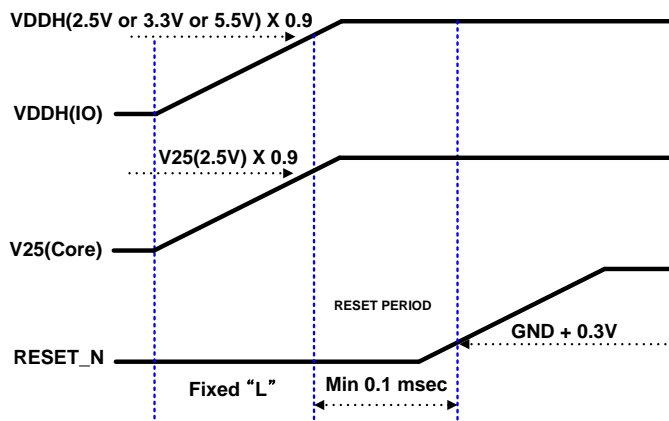

In order to make RESET_N delayed about 0.01msec of VDDH, 10K Ω resistor and 1uF capacitor are attached on RESET_N pin. Please see the typical application circuits above how to connect them.

Power State

ATA5088 supports two power states. When touch state gets detected, it enters the ACTIVE mode and AIC starts operating. Power consumption in this case is approximately 50uA. And if there is no touch input for the next 3 seconds, it switches to IDLE state. In this mode, fewer blocks are operating, thus it leads to less power consumption and is approximately 20uA. Even if there is no touch input when in IDLE state, it waits for 2 seconds and automatically goes to ACTIVE mode for calibration and comes back to IDLE state after finishing the calibration.

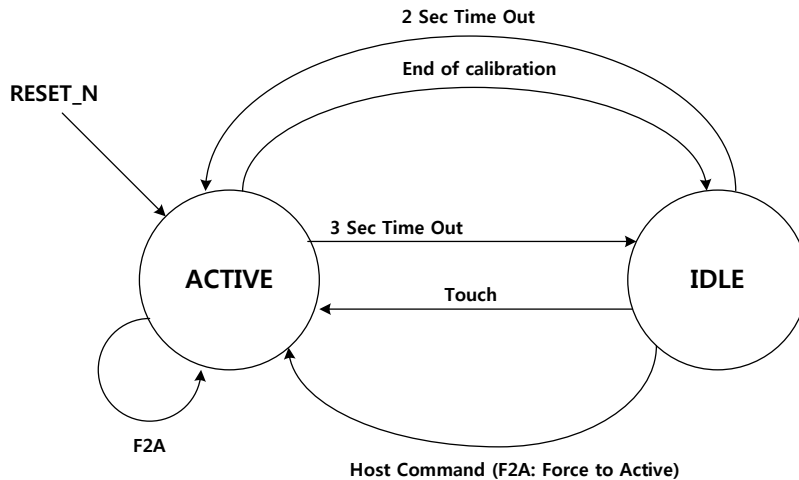

Figure 6: Power State Diagram

Tuning System

The tuning system helps the developer to tune the target board with various parameters that determine the performance of the target touch board. The tuning system is positioned between the PC and the target touch board (Figure). It allows the developer to view all the necessary parameters for tuning and transfers the desired parameters to the ATA5088 attached on the target touch board.

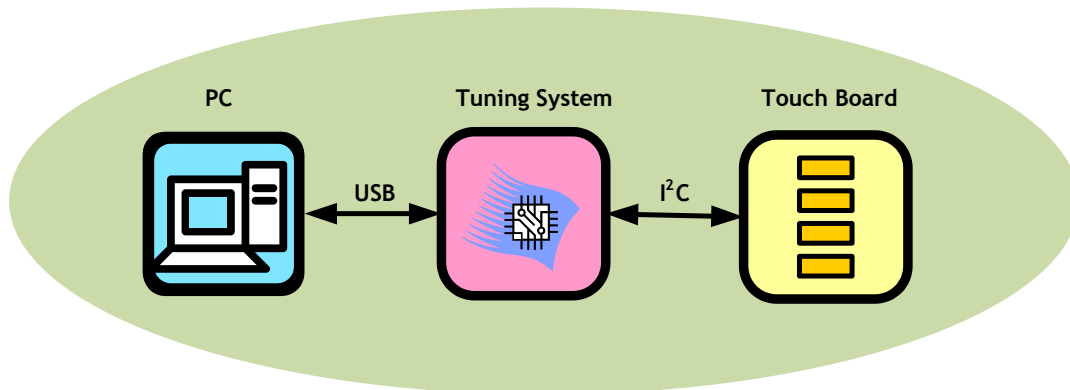

Figure 7: Conceptual Diagram for Tuning System

Hardware

Using this tuning system, the user can send commands to the MCU or receive touch data from the MCU through the USB interface board. The MCU on the USB interface board controls the ATA5088 on the target touch board via the I²C interface by reading/writing data to access internal registers in the ATA5088.

Software

The tuning software installed in the PC will display various registers to control and shows current impedance values of all input channels in real time. A typical tuning window is shown in Figure . For more information, please refer to the ATA5088 Application Guide which includes software installation, the usage of tuning viewer program and internal register information.

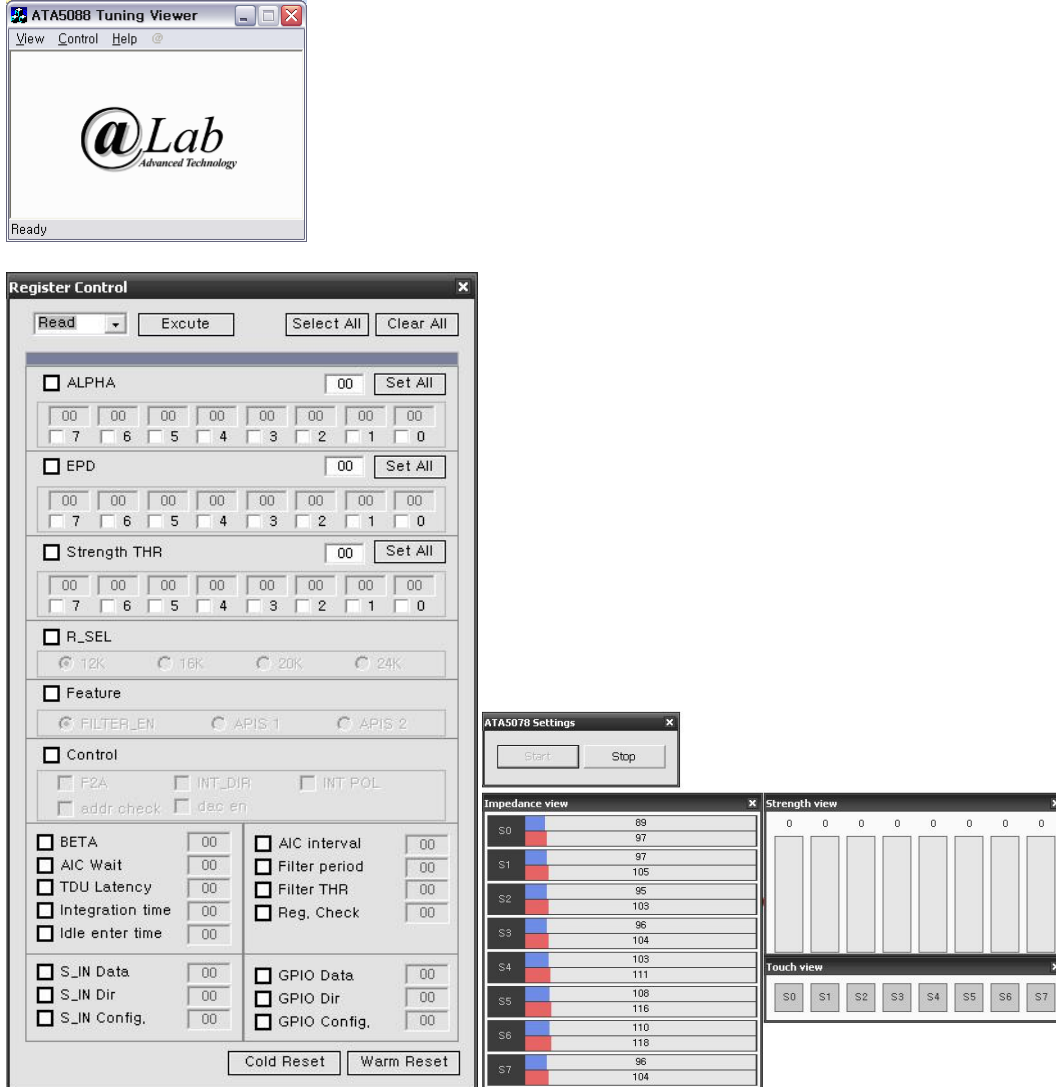
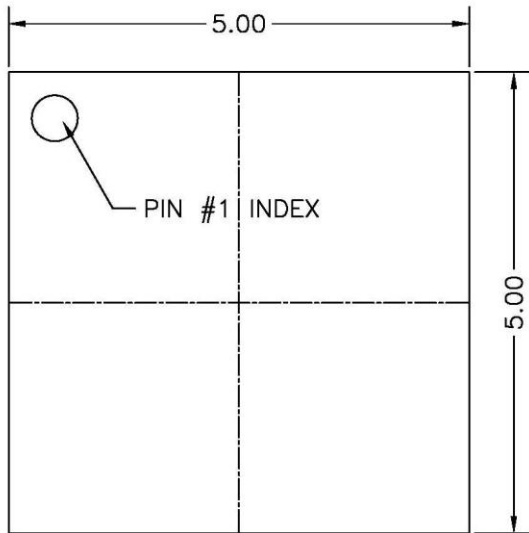

Figure 8: A Typical Tuning Window of Tuning Program

Package Dimensions

Units: mm

32QFN



TOP VIEW

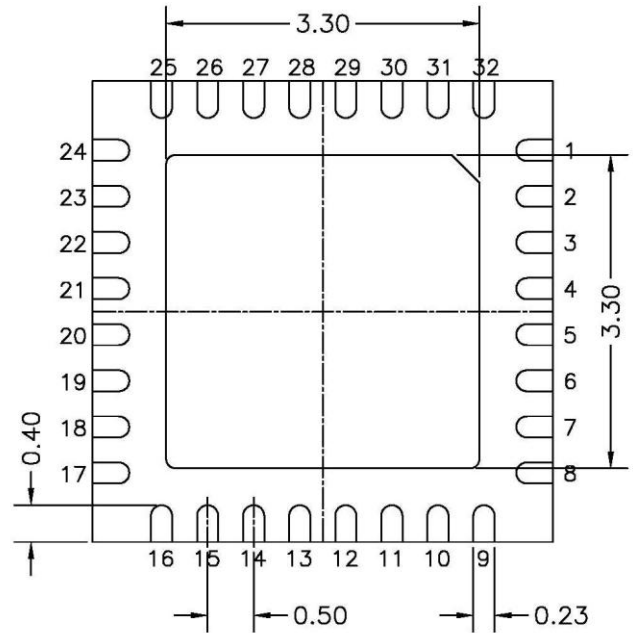

BOTTOM VIEW

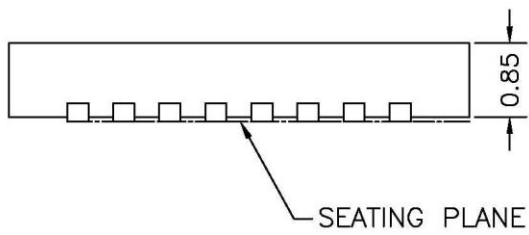

SIDE VIEW

16QFN

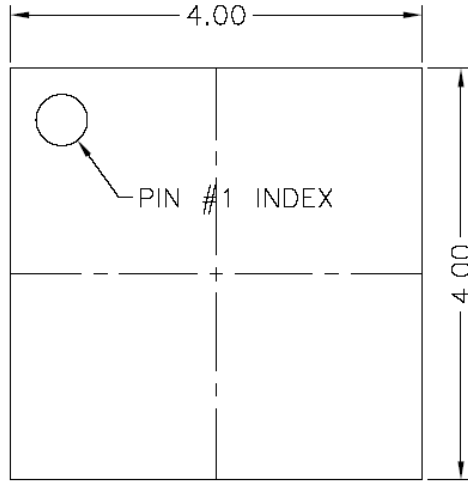

TOP VIEW

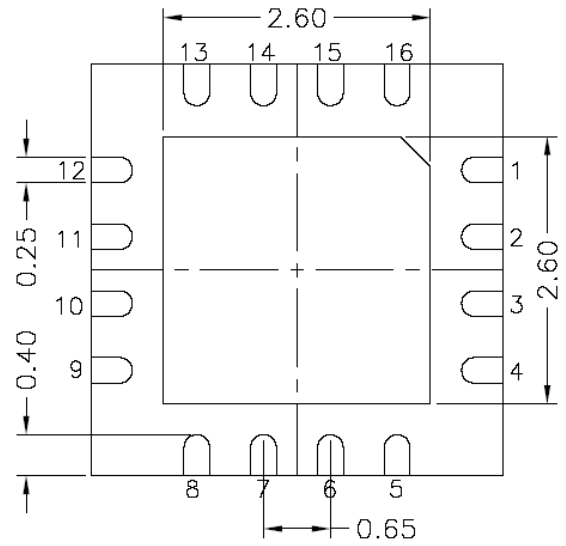

BOTTOM VIEW

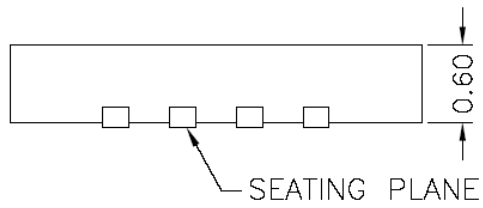

SIDE VIEW

24SSOP

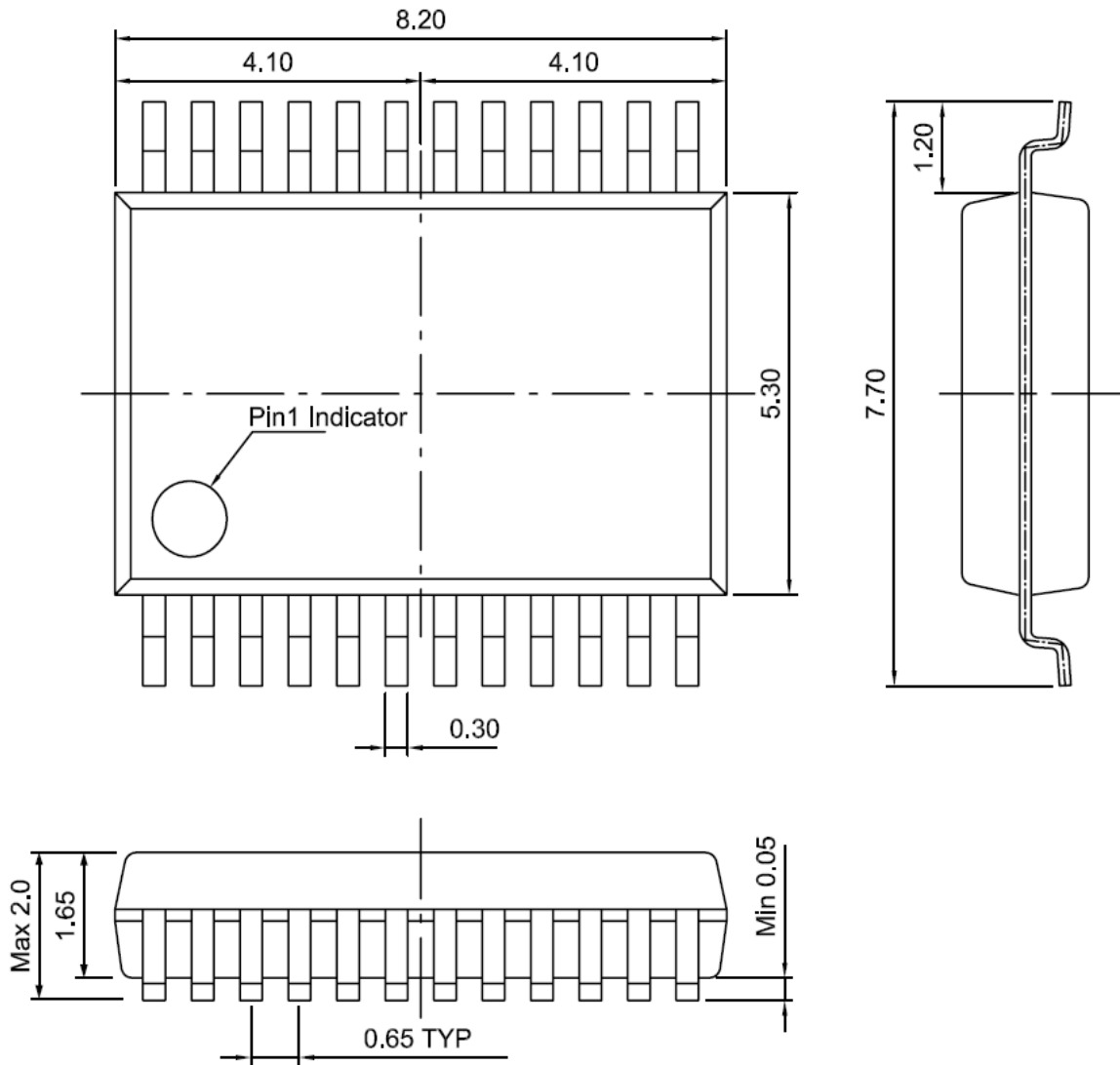

16SOP

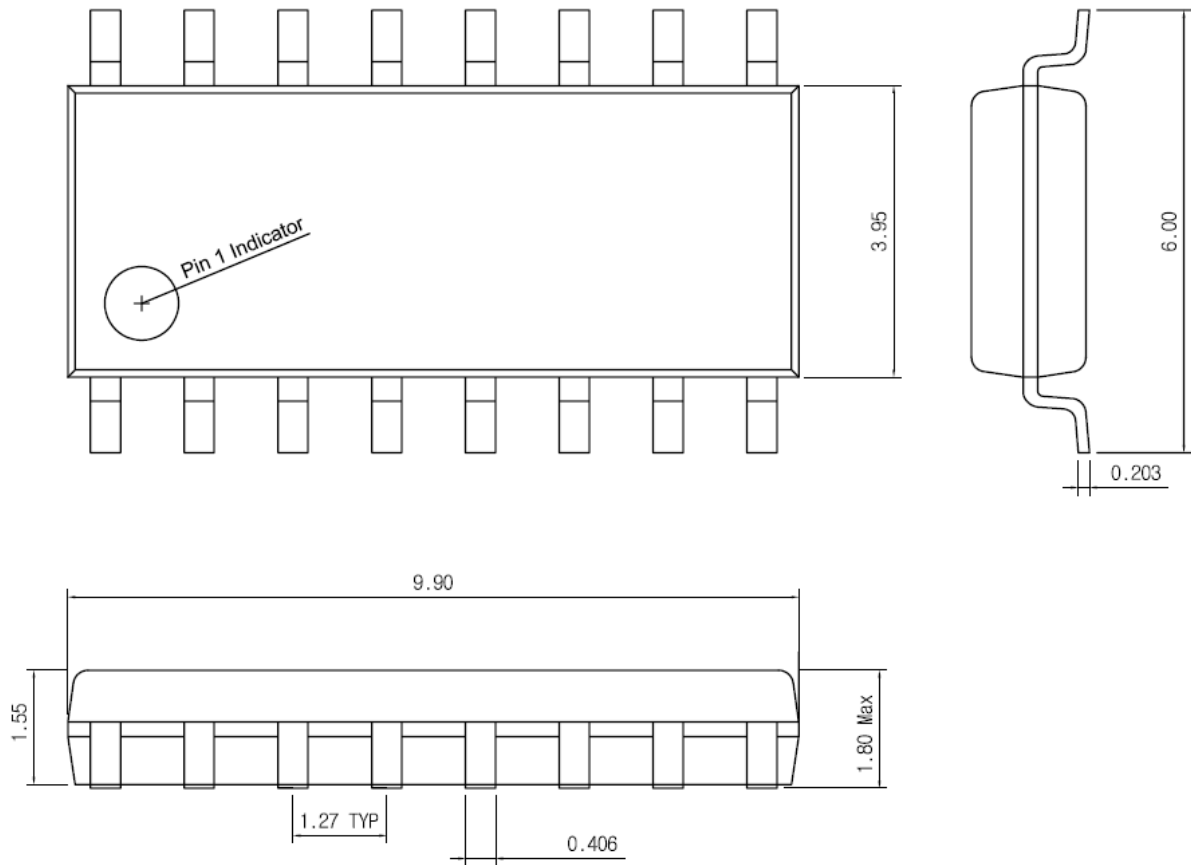

30SSOP

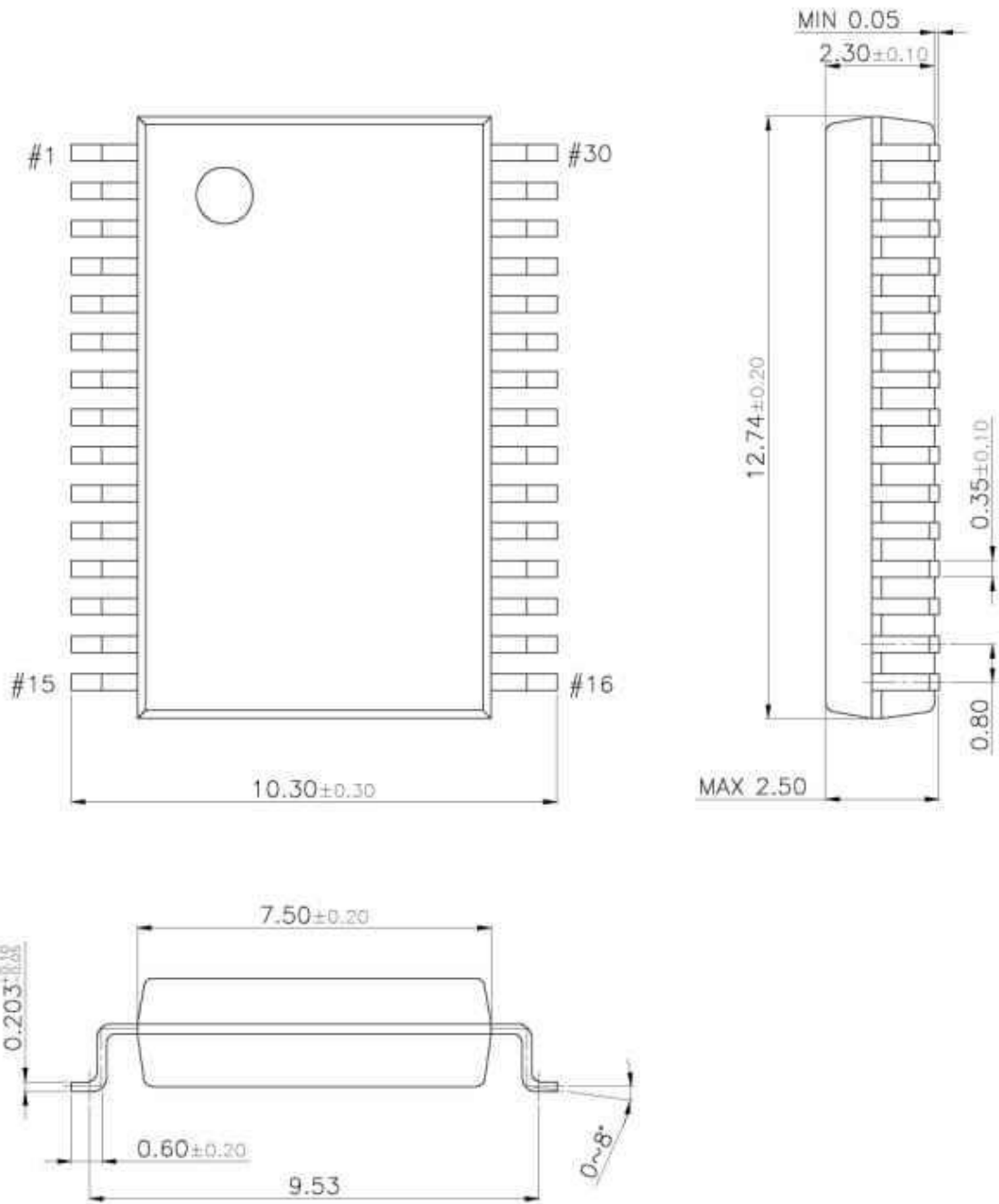

Product Inquiry

In Korea, **ATLab, Inc.**
4th Floor, MogAm Building, GreenCross
341 BoJeong-Dong, GiHeung-Gu, YongIn-Shi,
KyungGi-Do 446-799, Korea
Tel: +82 (31) 266-3082 Fax: +82 (31) 266-3083
Website: <http://www.atl21c.com>
E-mail: dcc@atlab.co.kr

In USA, **Act-On, Inc.**
2000 Wyatt Drive, Suite 1,
Santa Clara, CA 95054, USA
Tel: +1 (408) 748-7600 Fax: +1 (408) 748-3566
Website: <http://www.acton-usa.com>
E-mail: info@acton-usa.com

Notice

ATLab, Inc. (“@Lab”) reserves the right to change any products described herein at any time and without notice. @Lab assumes no responsibility or liability arising from the use of the products described herein, except as expressly agreed to in writing by @Lab. The use and purchase of this product does not convey a license under any patent rights, copyrights, trademark rights, or any other intellectual property rights of @Lab. Copyright 2008, ATLab, Inc. All rights reserved.